

# 2012

JEAN MÜLLER   
THE NAME FOR SAFETY

## PRODUCTS & SYSTEMS FOR THE ELECTRICITY INDUSTRY

*Catalogue and Trade Price List*





Jean Müller NZ Ltd.  
Unit 2, 37 Hurlstone Drive  
PO Box 907  
New Plymouth 4340  
NEW ZEALAND

Phone 06 769 9694  
Fax 06 769 9696

Website [www.jeanmueller.co.nz](http://www.jeanmueller.co.nz)  
Email [sales@jeanmueller.co.nz](mailto:sales@jeanmueller.co.nz)

Notes:

1. Unless otherwise indicated Jean Müller NZ Ltd will endeavour to maintain stock of all items in this price list.
2. All prices quoted in this price list are exclusive of GST
3. Returned Goods should be addressed to:  
Jean Müller NZ Ltd  
Unit 2, 37 Hurlstone Drive  
NEW PLYMOUTH  
Attn: Returns

## CONTENTS

		<i>Page</i>
JEAN MÜLLER	<i>About Us</i>	2
	<i>Fuses</i>	4
	<i>Fuse bases</i>	16
	<i>Vertical fuse disconnects</i>	18
	<i>Horizontal fuse disconnects</i>	26
	<i>Busbar systems</i>	37
	<i>Cabinets</i>	46
	<i>Metering solutions</i>	52
ENSTO	<i>Shear head bolt connectors and lugs</i>	54
MBS	<i>Current transformers</i>	58
FTG	<i>Power distribution blocks</i>	59
Technical Information		61
Dimensions		75
Terms and Conditions of Sale		105



JEAN MÜLLER was founded in 1897 in the village of Eltville on the banks of the Rhine River in Germany.

At this time the applications for electricity were still in their early days. Jean Müller chose as its basic activity the development of fuses.

Today the company has more than three hundred employees and works with modern production methods to produce fused switchgear, low voltage switchgear assemblies, current distribution components, electronic monitoring systems and energy management systems.

The combination of specialist knowledge of the electrical supply industry and the experience of a company that has been growing for more than 100 years means that JEAN MÜLLER is

**THE NAME FOR SAFETY**

Since the year 2000, JEAN MÜLLER has been represented in New Zealand by EMF Industrial Ltd however in March 2011 EMF Industrial became Jean Müller NZ Ltd, a fully owned subsidiary of Jean Müller GmbH.



### **Products**

Our tried and tested products comply with the international IEC standards and with the relevant national standards. They are manufactured in conformity with the highest quality requirements, and our quality management is certified according to DIN EN ISO 9001.

### **Solutions**

Our profession is the development and manufacture of products suitable for the entire electrical power distribution system in industry, within the power supply grid and in buildings. We also provide customized solutions for specific customer applications.

### **Service**

We offer to our customers specialised technical consulting tailored to their specific applications. Our more than 100 years of experience and technical know-how, including knowledge of specific national requirements worldwide, provide a solid basis of competence that spans from the consulting phase to manufacture and subsequent customer service.

We remain permanently available to our customers by means of our extensive service network - in Germany, Europe and other countries of the world. The data sheets, the dxf drawings and the product news are available for you around-the-clock on your homepage [www.jeanmueller.de](http://www.jeanmueller.de).

### **Current distribution for industrial applications**

Our current distribution components are used for electrical power supply in industrial applications, large buildings, office centres, factories, ships, airports and everywhere where protection against overload is essential.

For switchgear and controlgear panel builders, we are setting new standards with our SASIL and COSMO distribution systems.

### **Power distribution for electricity supply companies**

The "Power Distribution" product line covers all the requirements of electricity supply companies world-wide. The field of application is the public power supply system, including current distribution all the way from power station to house service connection.

### **System electronics**

Our "Powerlizer" product family provides system electronics for energy management. The "Powerlizer" range covers the full spectrum of products required for the acquisition, display, monitoring and evaluation of measurement data in the field of power distribution for industrial applications and the public power supply network.

## DIN-fuse-links



DIN fuse-links are used for the protection of electrical installations and equipment and are common for a wide area of applications.

Standardised characteristics, technical data and dimensions offer adapted solutions without complex individual calculations.

## DIN FUSE LINKS

		<i>Page</i>
DIN fuse links	<i>Fuse-links utilisation category gL/gG</i>	6
	<i>Striker fuses gL/Gg</i>	7
	<i>Fuse-links utilisation category aM for motor circuit protection</i>	8
	<i>Fuse-links utilisation category ufi</i>	9
Solid links and accessories	<i>TM**</i>	10
D-Type fuse links	<i>gL/gG</i>	11
Cylindrical fuse links	<i>gL/gG</i>	11
Metering fuse links	<i>gL/gG</i>	12
Fuses for DC applications		14



### Utilisation category gL/gG 500VAC with combi indicator



SM0000

Notes: DIN000 Fuses are suitable for mounting in DIN00 holders



SM00



SM1



SM2



SM3



SM4A

Size	Rating (A)	Power Dissipation (W)	Part No.	\$NZ
DIN 000	4A		SM000-GL/004	12.15
Refer Notes	10A		SM000-GL/010	12.15
	16A		SM000-GL/016	12.15
	20A		SM000-GL/020	12.15
	25A		SM000-GL/025	12.15
	32A		SM000-GL/032	12.15
	35A		SM000-GL/035	12.15
	40A		SM000-GL/040	12.15
	50A		SM000-GL/050	12.15
	63A		SM000-GL/063	12.15
	80A		SM000-GL/080	12.15
	100A		SM000-GL/100	12.15
DIN 00	125A		SM00-GL/125	15.20
	160A		SM00-GL/160	18.00
DIN 1	63A		SM1-GL/063	28.70
	80A		SM1-GL/080	28.70
	100A		SM1-GL/100	28.70
	125A		SM1-GL/125	28.70
	160A		SM1-GL/160	28.70
	200A		SM1-GL/200	30.90
	224A		SM1-GL/224	30.90
	250A		SM1-GL/250	30.90
DIN 2	63A		SM2-GL/063	31.85
	80A		SM2-GL/080	31.85
	100A		SM2-GL/100	31.85
	125A		SM2-GL/125	34.95
	160A		SM2-GL/160	34.95
	200A		SM2-GL/200	34.95
	250A		SM2-GL/250	40.45
	315A		SM2-GL/315	40.45
	355A		SM2-GL/355	40.45
	400A		SM2-GL/400	44.75
DIN 3	315A		SM3-GL/315	62.50
	400A		SM3-GL/400	62.50
	500A		SM3-GL/500	79.85
	630A		SM3-GL/630	85.10
	800A		SM3-GL/800	165.35
DIN 4a	400A		SM4A-GL/400	242.75
	500A		SM4A-GL/500	242.75
	630A		SM4A-GL/630	242.75
	800A		SM4A-GL/800	242.75
	1000A		SM4A-GL/1000	270.70
	1250A		SM4A-GL/1250	289.40
	1600A		SM4A-GL/1600	337.70



**Utilisation category gL/gG 500VAC with striker**



SM\*\*-\*\*K

Size	Rating (A)	Power Dissipation (W)	Part No.	\$NZ
DIN 000	16A		SM000-GL/016K	32.95
	20A		SM000-GL/020K	32.95
	25A		SM000-GL/025K	32.95
	32A		SM000-GL/032K	32.95
	40A		SM000-GL/040K	32.95
	50A		SM000-GL/050K	32.95
	63A		SM000-GL/063K	32.95
	80A		SM000-GL/080K	32.95
	100A		SM000-GL/100K	32.95
	DIN00	125A		SM00-GL/125K
160A			SM00-GL/160K	47.70
DIN 1	200A		SM1-GL/200K	80.65
	250A		SM1-GL/250K	80.65
DIN 2	315A		SM2-GL/315K	85.00
	400A		SM2-GL/400K	85.70
DIN 3	500A		SM3-GL/500K	115.15
	630A		SM3-GL/630K	122.45



### Utilisation category aM for motor protection 500VAC with combi indicator



SM\*\* -AM

Size	Rating (A)	Power Dissipation (W)	Part No.	\$NZ
DIN000	16A		SM000-AM/016	19.40
	20A		SM000-AM/020	19.40
	32A		SM000-AM/032	19.40
	40A		SM000-AM/040	19.40
	63A		SM000-AM/063	19.40
DIN00	80A		SM00-AM/080	25.55
	100A		SM00-AM/100	28.45
	125A		SM00-AM/125	32.75
	160A		SM00-AM/160	41.80
DIN 1	200A		SM1-AM/200	66.70
	250A		SM1-AM/250	66.70
DIN 2	315A		SM2-AM/315	122.80
	400A		SM2-AM/400	122.80
DIN 3	500A		SM3-AM/500	179.00
	630A		SM3-AM/630	195.30



SM\*\*-UF/

**Utilisation category aR 690VAC - üf<sub>1</sub> (very fast acting)**

Size	Rating (A)	Power Dissipation (W)	Part No.	\$NZ
DIN 000	16A		SM000-UF/016	47.65
	20A		SM000-UF/020	47.65
	25A		SM000-UF/025	47.65
	32A		SM000-UF/032	47.65
	40A		SM000-UF/040	49.90
	50A		SM000-UF/050	49.90
	63A		SM000-UF/063	51.90
	80A		SM000-UF/080	51.90
	100A		SM000-UF/100	56.40
	125A		SM000-UF/125	58.90
DIN 1	160A		SM000-UF/160	60.95
	200A		SM1-UF/200	161.50
DIN 2	250A		SM1-UF/250	161.50
	315A		SM2-UF/315	176.40
DIN 3	400A		SM2-UF/400	192.25
	500A		SM3-UF/500	217.70
	630A		SM3-UF/630	228.15



### Solid links 690VAC



TM

	Size	Rating (A)	Gripping Lugs	Power Dissipation (W)	Part No.	\$NZ
	DIN 00	160A	Insulated	2.0	TM00-ISM	16.30
	DIN 1	250A	Insulated	5.0	TM1-ISM	23.60
	DIN 2	400A	Insulated	10.0	TM2-ISM	27.70
	DIN 3	630A	Insulated	21.0	TM3-ISM	41.55
		1250A	Insulated	24.0	TM3-1250-ISM	64.65
	DIN 4a	1250A	Live	21.0	TM4A-1250	86.00
		1600A	Live	22.0	TM4A-1600	231.75

### Accessories



GPSHE

Size	Part No.	\$NZ
For fitting and removal of DIN 000, 00, 1, 2, 3 fuse links	GPSHE	39.25

### D-Type fuse links utilisation category gL/gG 500VAC



GLD

Size	Rating (A)	For thread	Power Dissipation (W)	Part No.	\$NZ
DII	10A	E27	2.1	GLD2/10	2.35
	16A	E27	2.5	GLD2/16	2.35
	20A	E27	2.6	GLD2/20	2.85
	25A	E27	3.3	GLD2/25	2.85
DIII	35A	E33	4.4	GLD3/35	4.75
	50A	E33	6.0	GLD3/50	4.75
	63A	E33	6.2	GLD3/65	4.75

### Cylindrical fuse links (house service fuses) gL/gG



SKR

Size	Rating (A)	Voltage	Power Dissipation (W)	Part No.	\$NZ
22 x 58mm	32A	690V	3.7	SKR-GL/032	7.30
22 x 58mm	40A	690V	4.5	SKR-GL/040	7.30
22 x 58mm	50A	690V	5.2	SKR-GL/050	7.65
22 x 58mm	63A	500V	6.9	SKR-GL/063	7.65
22 x 58mm	80A	500V	7.8	SKR-GL/080	8.85
22 x 58mm	100A	500V	8.6	SKR-GL/100	8.85

## NH metering fuse-links

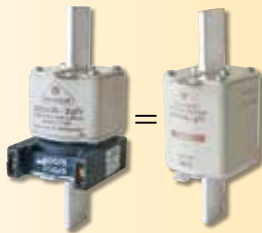

### Truncated size with additional feature

- Truncated isolating body with rated voltage AC400V
- Dimensions in conjunction with attached current transformer

### Attachable current transformers

- Dedicated current transformers offer two measuring ranges
- Current transformers allow open-ended operation

### Bimetallic current meters

- Dedicated bimetallic current meters with two measuring ranges and slave pointer

### Application in switchgear

- JEAN MÜLLER fuse disconnects are prepared to accept metering fuse-links

### Metering fuse links utilisation category gL/gG 400VAC

Size	Rating (A)	Power Dissipation (W)	Part No.	\$NZ
DIN2	200	12.0	SMCT2-GL/200	105.85
	250	17.0	SMCT2-GL/250	105.85
	315	20.0	SMCT2-GL/315	105.85
	400	24.0	SMCT2-GL/400	127.75
DIN3	400	24.0	SMCT3-GL/400	133.75
	630	32.0	SMCT3-GL/630	149.05

### Current transformers for metering fuse links

Size	Primary Current (A)	Secondary Current (A)	Power (VA)	Class	Part No.	\$NZ
DIN2	400/200	5	5/3.5	3	MSMK2/400/5	128.75
DIN3	400/200	5	5/3.5	3	MSMK3/400/5	138.95
DIN3	600/300	5	5/3.5	3	MSMK3/600/5	138.95
Circlip for securing CTs					SIBZ-R	1.25

### Bimetallic meters for metering fuse links (MDIs)

Size	Scale (A)	Measuring Range (A)	Part No.	\$NZ
DIN 1,2,3	400/200	0-5	SL-MDI-400	383.60
DIN 1,2,3	600/300	0-5	SL-MDI-600	383.60

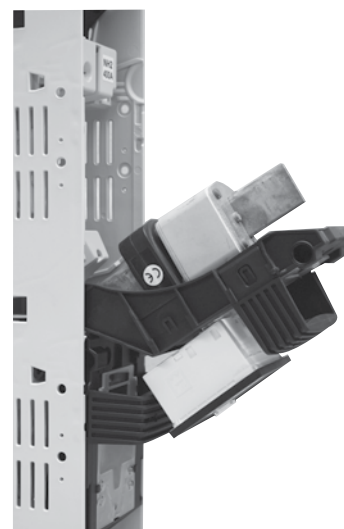

## NH fuse-links for DC applications



### Compact dimensions DC80V

- High current carrying capacity up to 800A
- Compact size NH00
- Suitable NH fuse-switch-disconnectors available



### Compact dimensions DC250V

- High current carrying capacity up to 315A
- Compact size NH00
- Suitable NH fuse-switch-disconnectors available

### Various applications

- DC80V especially for short circuit protection in power supply systems for telecommunication
- DC250V and DC440V for protection against overload and short circuit in common DC applications





### DIN00 fuse links 80VDC for telecommunication applications

Size	Rating (A)	Power Dissipation (W)	Part No.	\$NZ
DIN00	100	8.0	SM00-DC100	151.40
	160	9.0	SM00-DC160	151.40
	250*	12.0	SM00-DC250	169.60
	400*	18.0	SM00-DC400	169.60
	630*	28.0	SM00-DC630	169.60
	800*	39.0	SM00-DC800	169.60

### DIN00 fuse links 250VDC

Size	Rating (A)	Power Dissipation (W)	Part No.	\$NZ
DIN00	63	7.5	SM00-DC063/250	171.65
	100	9.4	SM00-DC100/250	171.65
	160	13.8	SM00-DC160/250	171.65
	200*	18.9	SM00-DC200/250	185.10
	250*	21.2	SM00-DC250/250	185.10
	315*	23.5	SM00-DC315/250	185.10

\* only for use with JEAN MÜLLER fuse disconnects type LTT.



### Fuse bases for DIN fuses

Size	For Fuses	Current Rating (A)	Terminal	Connection Capacity (mm <sup>2</sup> )	Part No.	\$NZ
DIN00	DIN000 & DIN00	160	Flat Terminal M8	max. 95	U00-1IG/H	30.15
DIN1	DIN1	250	Flat Terminal M10	max. 150	U1-1IGZ/H	84.75
DIN2	DIN2	400	Flat Terminal M12	max. 240	U2-1IGZ/H	96.75

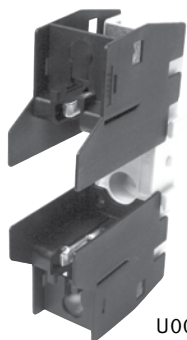

U00



U1

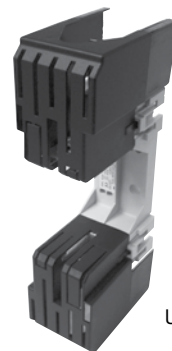

U2

### Fuse bases for cylindrical fuses

For Fuses	Current Rating (A)	Switch width (mm)	Terminal	Connection Capacity (mm <sup>2</sup> )	Part No.	\$NZ
10 x 38mm	32	18	Clamp	0.75 - 25	WH-AMB1/10	13.15
10 x 38mm	32	54	Clamp	0.75 - 25	WH-AMB3/10	40.55
22 x 58mm	125	36	Clamp	4 - 50	WH-AMB1/22	68.45
22 x 58mm	125	108	Clamp	4 - 50	WH-AMB3/22	171.80



WH-AMB1/10



WH-AMB3/10



WH-AMB1/22

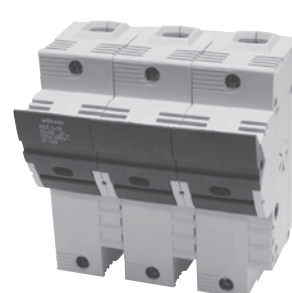

WH-AMB3/22



## Vertical fuse disconnects



### Vertical fuse disconnects

Vertical fuse disconnects are designed to receive NH fuse links. Hinged fuse-carriers enable opening and closing operation in electric circuits under load conditions. Thereby, the fuse-link or solid link forms the moving contact. Both, single pole and three-pole switching is possible.

Vertical fuse disconnects are used in Transformer stations and cable distribution cabinets of public utilities as well as low voltage switchgear and controlgear assemblies acc. to IEC/EN 60439-1. Their closed design and high breaking capacity make them extremely reliable and powerful fuse-combination units.



#### **Product definition**

Vertical fuse disconnects are three-pole fuse-switches for busbar mounting. They combine three single-pole fuse-switches longitudinally arranged in one unit. Each of the feeder terminals is directly connected to one phase of a three-phase busbar system. The outgoing terminals are equipped with terminals for cable conductors.

#### **Applications**

Vertical fuse disconnects conform to the requirements of public utilities and industrial companies for power distribution boards in ring main units, transformer substations, cable distribution cabinets as well as main distribution boards. Vertical fuse disconnects having built-in current transformers are essential devices for efficient energy management. With built-in fuse monitoring function they ensure short reaction time even in decentralized power distribution systems.

#### **Product advantages**

JEAN MÜLLER vertical fuse disconnects are available in sizes 00 to 3 for both single pole and three-pole switching operation. Product versions with built-in current transformers, feeder units up to 2000A rated current, and a wide range of specially designed products enable efficient and reliable power distribution.

#### **Insulation parts**

All insulating parts are made of high mechanical strength polymers are resistant to breaking, self extinguishing and halogen-free. The fuse-base insulator for 185mm busbar systems, which supports the current carrying parts, is made of high stability glass fibre reinforced thermosetting polyester, according to power utility specifications.

#### **Current carrying parts**

Silver-plated receiving contacts for DIN fuse-links ensure low power loss, optimum temperature behaviour and high breaking capacity. The tin-plated down leads are available with different types of terminals.

Thanks to the contact covers that provide safety from touch by the back of the hand, the products can be mounted on live busbar systems, provided the local safety rules allow for. The upper parts of vertical fuse disconnects including the fuse carriers can be easily mounted and fixed by means of turn-lock fasteners.

#### **Product versions/Accessories**

The products prepared for current transformers can be equipped with specifically designed current transformers inserted in the base insulator. Current transformers are available for primary currents ranging from 50A to 1000A.



SL00-3X3/100F/HA



SL00-3X3/185F



SL1G-3X3/3A  
SL2G-3X3/3A  
SL3-3X3/3A



SL3-3X3/1000HA



SL3-3X6/1250/HA



SL00-3X/100F/HA



SL00-3X/185F



SL1G-3X/3A  
SL2G-3X/3A  
SL3-3X/3A



SL3-3X/1000HA



SL3-3X2/1250/HA

### Vertical fuse disconnects 3 pole switching in one action

Size	For Fuses	Current Rating (A)	Switch width (mm)	Busbar Centre Spacing (mm)	Part No.	\$NZ
DIN 00	DIN 000 & DIN00	160A	50 mm	100 mm	SL00-3X3/100F/HA	217.85
DIN 00	DIN 000 & DIN00	160A	50 mm	185 mm	SL00-3X3/185F	267.45
DIN 1	DIN 1	250A	100 mm	185 mm	SL1G-3X3/3A	601.65
DIN 2	DIN 2	400A	100 mm	185 mm	SL2G-3X3/3A	628.75
DIN 3	DIN 2 & DIN 3	630A	100 mm	185 mm	SL3-3X3/3A	692.80
	Solid Links	1000A (solid links only)	100 mm	185 mm	SL3-3X3/1000/HA	1,039.50
	DIN 2 & DIN 3 (2)	1250A	200 mm	185 mm	SL3-3X6/1250/HA	1,887.00

### Vertical fuse disconnects 3 pole individual pole switching

Size	For Fuses	Current Rating (A)	Switch width (mm)	Busbar Centre Spacing (mm)	Part No.	\$NZ
DIN 00	DIN 000 & DIN00	160A	50mm	100mm	SL00-3X/100F/HA	217.85
DIN 00	DIN 000 & DIN00	160A	50 mm	185 mm	SL00-3X/185F	267.45
DIN 1	DIN 1	250A	100 mm	185 mm	SL1G-3X/3A	545.00
DIN 2	DIN 2	400A	100 mm	185 mm	SL2G-3X/3A	586.50
DIN 3	DIN 2 & DIN 3	630A	100 mm	185 mm	SL3-3X/3A	664.15
	Solid Links	1000A (solid links only)	100 mm	185 mm	SL3-3X/1000/HA	963.50
	DIN 2 & DIN 3 (2x)	1250A	200mm	185 mm	SL3-3X2/1250/HA	1,796.55
	DIN 2 & DIN 3 (2x)	1600A	200mm	185 mm	SL3-3X2/2000/HA	2,779.10

### Vertical fuse buscouplers 3 pole switching in one action

Size	For Fuses	Current Rating (A)	Switch width (mm)	Busbar Centre Spacing (mm)	Part No.	\$NZ
DIN3	Solid Links	1000A (solid links only)	100 mm	185 mm	SLT3-3SL/3X3 /1000	1,039.80



REAR VIEW  
With CTS Fitted



SL1G-3X3/W/3A  
SL2G-3X3/W/3A  
SL3 -3X3/W/3A

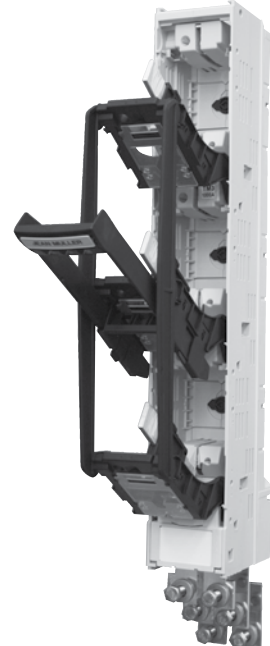

SL3-3X3/1000W/HA



SL1G-3X/W/3A  
SL2G-3X/W/3A  
SL3-3X/W/3A



SL3-3X/1000W/HA



### Vertical fuse disconnects with CT mount facility - 3 pole switching in one action

Size	For Fuses	Current Rating (A)	Switch width (mm)	Busbar Centre Spacing (mm)	Part No.	\$NZ
DIN1	DIN1	250	100	185	SL1G-3X3/W/3A	697.45
DIN2	DIN2	400	100	185	SL2G-3X3/W/3A	725.75
DIN3	DIN2 & DIN3	630	100	185	SL3-3X3/W/3A	798.60
	Solid Links	1000A (Solid links only)	100	185	SL3-3X3/1000W/3A	1,145.05

### Vertical fuse disconnects with CT mount facility - 3 pole individual pole switching

Size	For Fuses	Current Rating (A)	Switch width (mm)	Busbar Centre Spacing (mm)	Part No.	\$NZ
DIN1	DIN1	250	100	185	SL1G-3X/W/3A	624.70
DIN2	DIN2	400	100	185	SL2G-3X/W/3A	673.40
DIN3	DIN2 & DIN3	630	100	185	SL3-3X/W/3A	762.55
	Solid Links	1000A (Solid links only)	100	185	SL3-3X/1000W/3A	1,056.85

### Current transformers for above





				Ratio	Part No.	\$NZ
				250:5	WKD51/1/250-5	68.15
				400:5	WKD51/1/400-5	68.15
				600:5	WKD51/1/600-5	68.15
				1000:5	WKD52/1/1000-5	120.10



## Accessories

Description	For Mounting on	Part No.	\$NZ
<b>Prism clamp</b>			
10-70 mm <sup>2</sup> Al/Cu	SL00	P0070	9.60
<b>Clip terminal</b>			
1,5-70 mm <sup>2</sup> Cu	SL00	S00	2.50
<b>Direct terminal clamp KM2G..</b>			
50-300 mm <sup>2</sup> Al/Cu	SL1-3	KM2G-AF30-40	29.85
<b>Direct terminal clamp</b>			
70-240 mm <sup>2</sup> Al/Cu	SL1-3	K2G/A	26.80
<b>Direct terminal clamp</b>			
2 conductors 50-120 mm <sup>2</sup> Al/Cu	SL1-3	K2HG/2/AF30	47.25
2 conductors 120-185 mm <sup>2</sup> Al/Cu	SL1-3	KV2HG/2/AF30	49.45
<b>Cover for clamp</b>			
For V-type box clamp type KM2G		HRV	7.85
For clamp type K2G/A, K2HG/ and KV2HG		HR	8.90

## Accessories

Description		For Mounting on	Part No.	\$NZ
	Terminal cover			
	For SL00-185	SL00/185	HA/H0-SL00/185	21.50
	For SL123	SL1-3	HA/SL123/10	30.35
	For SL3-3x/1000 Extended depth	SL3	HA220-SL123/10	89.35
	Terminal extension kit			
	Terminal for 3x300mm <sup>2</sup>	SL1-3	VS-SL3/1000	181.90
	Handle connecting kit			
	For ganged disconnecter	SL3	VBS-SL3X2(6)	9.75
	Fuse cover with symbol "Do not switch"			
	Size 00		SZ00-R	19.95
	Size 1-3		SZ123-R	33.90
	Cover holder			
	Set of 4 blocks	SL00-3	AH-SL	21.75



## Horizontal fuse disconnects



### Horizontal fuse disconnects

Horizontal fuse Disconnects are used in building installations, switchgear and controlgear as well as in power utility networks. The contact system enables safe load break operation using the fuse-links as moving contacts.

The product is safe against finger-touch in closed position and provides a safe and visible isolating distance in open position. Different versions for baseplate mounting, DIN-rail or busbar mounting are available to fit a variety of applications.



### Product definition

Horizontal fuse disconnect according to EN60947-3 are single-pole or multipole NH fuse-bases arranged horizontally and equipped with a common fuse-carrier.

Incoming and outgoing contacts are accessible from outside and fitted with terminals for the connection of cables or bars. The feeder side of fuse-switches for busbar mounting is designed to provide mechanical and electrical connection to standardised busbar systems.

### Applications

Its compact design makes the horizontal fuse disconnect a perfect feeder switch in low voltage distribution panels, as well as a protective device mounted on standardized busbar systems having 40mm, 60mm or 100mm busbar distance or for meter protection in domestic buildings. Single-pole and two-pole fuse-switches are used for UPS battery protection or in telecom power supplies e.g. 4-pole fuse-switches can be used to disconnect secondary power generators from public networks.

### Product advantages

JEAN MÜLLER offers NH fuse-switches in sizes 000, 00, 1, 2, 3 and 4a. The switches size 00, 1, 3 and 4a are available in single-pole up to 4-pole design. Executions for baseplate mounting as well as for busbar mounting are available in all sizes. Thanks to the wide product range, tailor-made solutions with respect to current rating, voltage rating and mode of installation can be found for nearly every application.

### Insulation parts

Similar to the vertical fuse disconnects all products from size 1 and above, contain only thermosetting materials for insulators supporting live parts because of their high dimensional stability and superior resistance to tracking.

### Current carrying parts

Products having rated currents of 400A and above, are equipped with Q-contacts for quasi-independent operation. Q-contacts ensure high short-circuit capability up to 80kA and safe load-break operation. Particularly NH fuse-switches for busbar mounting without separate adapters exhibit very low values for power loss due to their short connecting bars.

### Versions/Accessories

Monitoring components allow remote monitoring of switch-position as well as of fuse-links. Microswitches or electronic components will be used for fuse monitoring, depending on the application.

Special executions enable size 00 fuse-switches up to 800A rated current in combination with the corresponding fuse-links, thus providing significant savings in space.

1-pole and 3-pole disconnectors up to 1200V, protected against direct access to live parts and safe in operation, provide electric protection of solar power installations.



## Horizontal fuse disconnects for panel mounting



### General-purpose terminal

- All sizes are equipped with general-purpose flat terminals for cable lugs and direct terminal clamps

### Reliable overreach protection

- Optimum touch protection including when feeding from bottom side by retrofit overreach protector

### High short-circuit capability

- Fuse protected conditional short-circuit current up to 80kA
- 35kA/1s short-circuit withstand when equipped with solid links

### 1 pole horizontal fuse disconnects



LTL1-1/9

Size	For Fuses	Current Rating (A)	Terminal	Connection Capacity(mm <sup>2</sup> )	Part No.	\$NZ
DIN 00	DIN 000 & DIN00	160	Flat terminal M8	max. 95	LTL00-1/9	59.10
DIN 1	DIN 1	250	Flat terminal M10	max. 150	LTL1-1/9	214.35
DIN 3	DIN 2 & DIN 3	630	Flat terminal M10	max. 300	LTL3-1/9	341.30
DIN 4A	DIN4A	1250	Flat terminal M16	max. 400	LTL4A-1X/9/1250	653.05
DIN 4A	DIN4A	1600	Flat terminal 2x M12		LTL4A-1X/9/1600	697.40

### 2 pole horizontal fuse disconnects



LTL00-2/9

Size	For Fuses	Current Rating (A)	Terminal	Connection Capacity(mm <sup>2</sup> )	Part No.	\$NZ
DIN 00	DIN 000 & DIN00	160	Flat terminal M8	max. 95	LTL00-2/9	114.05
DIN 1	DIN 1	250	Flat terminal M10	max. 150	LTL1-2/9	368.65
DIN 3	DIN 2 & DIN 3	630	Flat terminal M10	max. 300	LTL3-2/9	632.40

### 3 pole horizontal fuse disconnects

Size	For Fuses	Current Rating (A)	Terminal	Connection Capacity(mm <sup>2</sup> )	Part No.	\$NZ
DIN 000	DIN000	100	Flat terminal M8	max. 95	LTL000-3/9	91.70
DIN 00	DIN000 & DIN00	160	Flat terminal M8	max. 95	LTL00-3/9	115.10
DIN 1	DIN 1	250	Flat terminal M10	max. 150	LTL1-3/9	376.15
DIN 2	DIN 2	400	Flat terminal M10	max. 240	LTL2-3/9	506.50
DIN 3	DIN 2 & DIN 3	630	Flat terminal M10	max. 300	LTL3-3/9	660.00
DIN4A	DIN4A	1250	Flat terminal M16	max. 400	LTL4A-3x3/9/1250	1,946.05
DIN4A	DIN4A	1600	Flat terminal M12		LTL4A-3x3/9/1600	2,070.45

LTL4A-3X3/\*\*

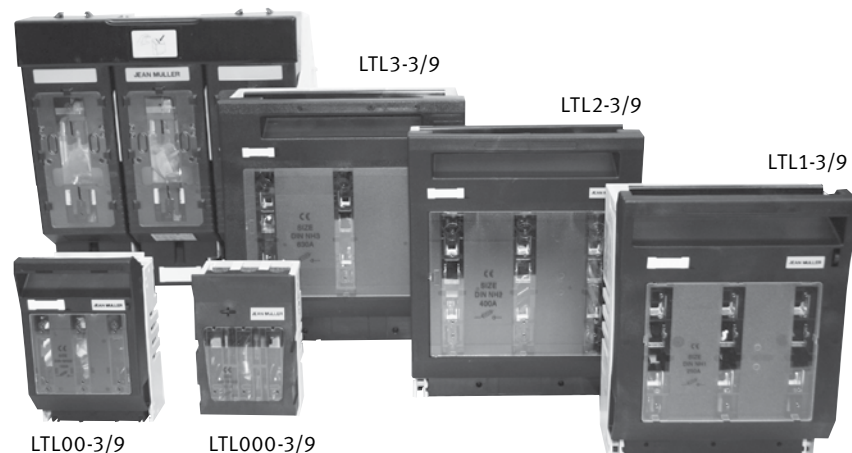



## Horizontal fuse disconnects for busbar mounting



### Adaptor free installation

- Small installation depth and direct busbar connection ensure low power loss

### One device fits three busbar systems

- Only one device size 00 for 40, 50 or 60mm busbar systems
- Fast installation by means of twist-lock mounting

### Compact size 000 fuse-switch

- Space saving 63mm width
- Easy snap-on technique without screws
- For busbars having 5mm or 10mm thickness

### Combinations of different sizes possible

- Uniform installation depth of 60mm above busbar surface by means of stepped frames of sizes 00 to 3
- Various protective covers provide a high safety level



### 1 pole horizontal fuse disconnects - busbar mount

Size	For Fuses	Current Rating (A)	Cable Connection	Connection Capacity(mm <sup>2</sup> )	Connection to Busbars	Part No.	\$NZ
DIN 00	DIN 000 & DIN00	160	Bottom	max. 95	Clamp	LTL00-1/SK/AU	76.35
DIN 1	DIN 1	250	Bottom	max. 150	Screw connection to busbar	LTL1-1/AU	242.30
DIN 3	DIN 2 & DIN 3	630	Bottom	max. 300	Screw connection to busbar	LTL3-1/AU	390.10

### 1 pole horizontal fuse disconnects - 60mm centres busbar mount

Size	For Fuses	Current Rating (A)	Cable Connection	Connection Capacity(mm <sup>2</sup> )	Connection to Busbars	Part No.	\$NZ
DIN 000	DIN000	100	Clamp	1.5 - 50	Snap-on	LTL000-3/9/60/F57/5	147.00
DIN 00	DIN000 & DIN00	160	Top or bottom	1.5 - 70	Clamp	LTL00-3/9/4060S	155.60
DIN 1	DIN 1	250	Bottom	max. 150	Clamp	LTL1-3/9/60AU	438.30
DIN 2	DIN 2	400	Bottom	max. 240	Clamp	LTL2-3/9/60AU	668.60
DIN 3	DIN 2 & DIN 3	630	Bottom	max. 300	Clamp	LTL3-3/9/60AU	753.00

### 3 pole horizontal fuse disconnects - 100mm centres busbar mount

Size	For Fuses	Current Rating (A)	Cable Connection	Connection Capacity(mm <sup>2</sup> )	Connection to Busbars	Part No.	\$NZ
DIN 1	DIN 1	250	Bottom	max. 150	Screw connection to busbars	LTL1-3/9/100AU	490.20
DIN 2	DIN 2	400	Bottom	max. 240	Screw connection to busbars	LTL2-3/9/100AU	724.35
DIN 3	DIN 2 & DIN 3	630	Bottom	max. 300	Screw connection to busbars	LTL3-3/9/100AU	807.00



## Horizontal fuse disconnects - Special versions



### Fuse-switch-disconnectors for baseplate monitoring

- For fuse-protected feeding of plug-in modules
- Fast module changing without cable disconnecting



### Disconnectors rated 1000V and above

- Proven technology for reliable operation of switchgear rated 1000V and above



### Space-saving protection of DC-systems up to 1000V

- 1-pole disconnecter for safe feeding of photovoltaic installations



### Compact switching devices up to DC 250V rating

- Minimum space required for fuse protection up to 800A with LTT size 00
- Versions for baseplate and busbar mounting as well as feeding on rear side

**1 pole horizontal fuse disconnects for telecom supplies up to 250V DC base mounting**

Size	For Fuses	Current Rating (A)	Connection	Terminal	Part No.	\$NZ
DIN 00	DC	800	Top and bottom	Flat Terminal M12	LTL00-1/9	206.65
DIN 00	DC	800	Rear	Flat Terminal M12	LTT00-1/9R	261.85





## Accessories

Description	Size	Part No.	\$NZ
-------------	------	----------	------



Clamp terminal			
1,5-70 mm <sup>2</sup> Cu	LTL00	S00	2.50
25-150 mm <sup>2</sup> Cu	LTL1	S1	3.95
25-240 mm <sup>2</sup> Cu	LTL2	S2	6.05
Bar 11 x 21	LTL3	S3	8.40



Prism clamp			
10-70 mm <sup>2</sup> Al/Cu	LTL00	P0070	9.60
70-150 mm <sup>2</sup> Al/Cu	LTL1	P1	16.35
120-240 mm <sup>2</sup> Al/Cu	LTL2	P2	20.45
120-300 mm <sup>2</sup> Al/Cu	LTL3	P3	26.20



Prism clamp for 2-conductors connection			
2 x 70-95 mm <sup>2</sup> Al/Cu	LTL1	P12	26.30
2 x 120-150 mm <sup>2</sup> Al/Cu	LTL2	P22	32.15
2 x 120-240 mm <sup>2</sup> Al/Cu	LTL3	P32	42.45



Switch position indicator			
1- and 3- pole	LTL00	EV-LTL00-3	22.35
1-pole	LTL1-3	EV-LTL123-1	24.70
3-pole	LTL1-3	EV-LTL123-3	35.40



Switch position indicator and fuse blown indicating microswitch			
1- and 3- pole	LTL4a	K/EV-LTL4a	45.70



Fuse blown indicating microswitch			
1-pole	LTL00	K-LTL00-1/H	30.50
1-pole	LTL1	K-LTL1-1/H	41.15
1-pole	LTL3	K-LTL3-1/H	61.15
3-pole	LTL00	K-LTL00-3/H	56.00
3-pole	LTL1	K-LTL1-3/H	138.45
3-pole	LTL2	K-LTL2-3/H	142.45
3-pole	LTL3	K-LTL3-3/H	152.95

## Accessories

Description	For Mounting on	Part No.	\$NZ
-------------	-----------------	----------	------



Protective cover, 1-pole, baseplate mounting			
Top and bottom side	LTL00	GOU-LTL00-1	4.85
Top and bottom side	LTL1	GOU-LTL1-1	8.00
Top and bottom side	LTL3	GOU-LTL3-1	12.15



Protective cover, 3-pole, baseplate mounting			
Top and bottom side	LTL00	GOU-LTL00-3	6.15
Top side	LTL1	GO-LTL1-3	6.55
Top side	LTL2	GO-LTL2-3	9.35
Top side	LTL3	GO-LTL3-3	12.85
Bottom side	LTL1	GU-LTL1-3	6.55
Bottom side	LTL2	GU-LTL2-3	9.35
Bottom side	LTL3	GU-LTL3-3	12.85



Protective cover 3-pole, busbar mounting			
Top side	LTL00	GOV-LTL00-3/230	8.60
Top side	LTL1	GOV-LTL1-3	8.60
Top side	LTL2	GOV-LTL2-3	9.65
Bottom side	LTL00	GUV-LTL00-3/230	8.60
Bottom side	LTL1	GUV-LTL1-3	8.60
Bottom side	LTL2	GUV-LTL2-3	9.65



## Comb busbars

FTG comb type busbars are constructed of three copper conductors within a single moulding for connection to Jean Müller LTL000-3/9 or LTL00-3/9 horizontal fuse disconnects.

The busbar is rated at 250amps.

Removable end caps allow the busbar to be shortened to intermediate sizes if required.

Description	Part No.	\$NZ
<b>Busbar for LTL000-3/9 100A disconnects</b>		
For connection to 3 disconnects	FTG-LTL000-3	84.40
For connection to 5 disconnects	FTG-LTL000-5	139.55
<b>Busbar for LTL00-3/9 160A disconnects</b>		
For connection to 3 disconnects	FTG-LTL00-3	79.80
For connection to 5 disconnects	FTG-LTL00-5	131.75
<b>Feed terminal</b>		
For cables up to 95mm <sup>2</sup> (3x required per disconnect)	FTG-LTL00/F	29.50
<b>Terminal covers</b>		
To provide finger protection to disconnect terminals fitted with FTG Busbars		
For LTL00	GO-LTL00-FTG	10.15
For LTL000	Cover not available	

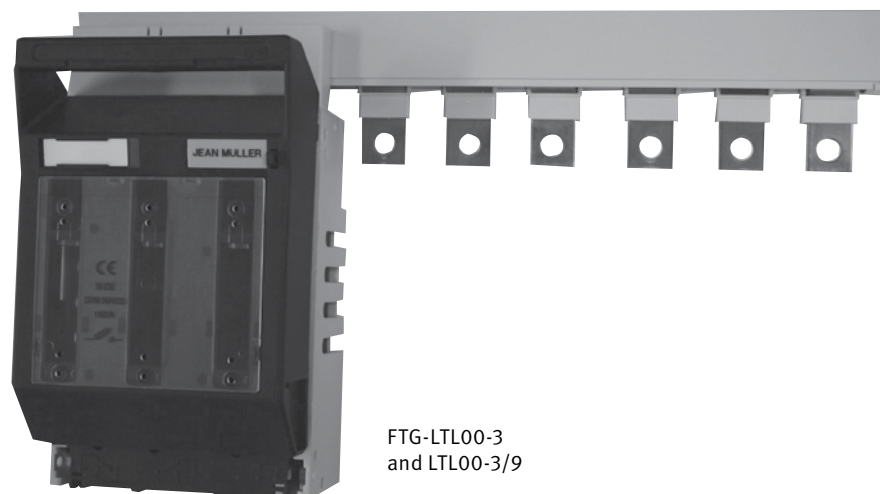

FTG-LTL00-3  
and LTL00-3/9

## C/O/S/M/O® 60mm busbar-system

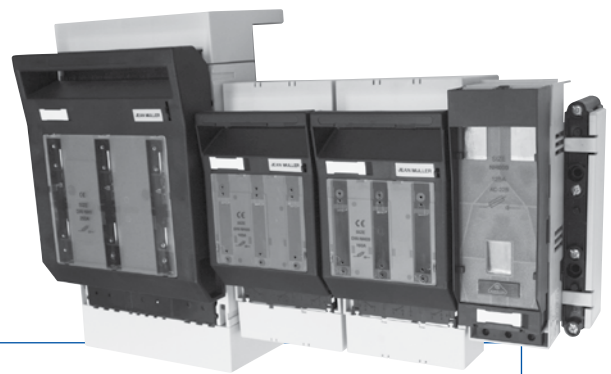

### Busbar supports

- Two-piece busbar supports adjustable to different busbar width with means of integrated adjusting element



### Busbar cover

- Clip on busbar covers are used for the protection of 3-pole and 4-pole busbar systems
- They are extendable or detachable at anytime. In addition they offer variable covering widths without measuring and cutting



### Connection modules

- Connection modules connect the busbars to power supply and protect against unintentional access to live parts
- Integrated robust clamps establish electrical contact



### C|O|S|M|O® system components

Description	Part No.	\$NZ
<b>Busbar support</b>		
3-pole	SST-60/49-3	33.90
<b>End cover</b>		
3-pole	A-SST-60/3	8.55
<b>Busbar cover</b>		
3-pole	SAD60/3	8.90
<b>Connecting modules up to 250A</b>		
3-pole 1,5mm <sup>2</sup> -70mm <sup>2</sup>	AM-60/250/3	85.25
<b>Connecting modules up to 630A</b>		
3-pole 70mm <sup>2</sup> -300mm <sup>2</sup>	AM-60/630/3	275.60

### 3 pole horizontal fuse-disconnects - 60mm centres busbar mount

Size	For Fuses	Current Rating (A)	Cable Connection	Connection Capacity(mm <sup>2</sup> )	Connection to Busbars	Part No.	\$NZ
DIN000	DIN000	100	Clamp	1.5-50	Snap-on	LTL000-3/9/60/F57/5	147.00
DIN00	DIN000 & DIN00	160	Top or bottom	1.5-70	Clamp	LTL00-3/9/4060S	155.60
DIN1	DIN1	250	Bottom	max. 150	Clamp	LTL1-3/9/60AU	438.30
DIN2	DIN2	400	Bottom	max. 240	Clamp	LTL2-3/9/60AU	668.60
DIN3	DIN2 & DIN3	630	Bottom	max. 300	Clamp	LTL3-3/9/60AU	753.00

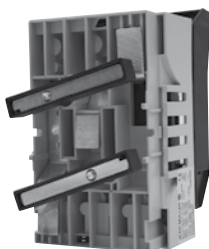

LTL00-3/9/4060/S

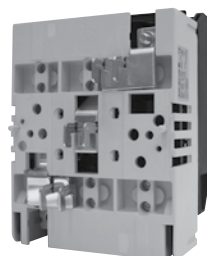

LTL1-3/9/60/AU



## C|O|S|M|O® 60mm busbar system

Load disconnect switches for D-type fuses 63A

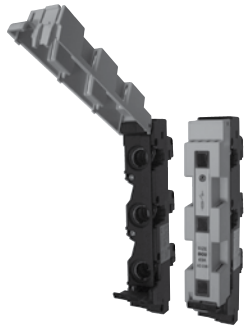

DSL-60/183-5

For Fuses	Current Rating (A)	Cable Connection	Connection Capacity(mm <sup>2</sup> )	Connection to Busbars	Part No.	\$NZ
D02	63	Clamp	max. 25	Snap-on	DSL-60/183-5	137.80
Screw cap					K02	6.85

Fuse bases for D-type fuses -25A



RS-60/333-5

For Fuses	Current Rating (A)	Cable Connection	Connection Capacity(mm <sup>2</sup> )	Connection to Busbars	Part No.	\$NZ
DII	25	Clamp	max. 25	Snap-on	RS-60/273-5	26.75
Front Cover					ARS-273/230	4.95
Top or bottom end cover					GOURS273-230	4.20
Left or right side cover					ASRS-230	4.45
Screw Cap					K2	4.65

Fuse bases for D-type fuses -25A



RS-60/273-5

For Fuses	Current Rating (A)	Cable Connection	Connection Capacity(mm <sup>2</sup> )	Connection to Busbars	Part No.	\$NZ
DIII	63	Clamp		Snap-on	RS-60/333-5	37.80
Front Cover					ARS-333/230	5.85
Top or bottom end cover					GOURS333-230	4.20
Left or right side cover					ASRS-230	4.45
Screw Cap					K2	7.85

## 100mm busbar system



WH-BSC/3P

### 100mm busbar system components

Description			Part No.	\$NZ
3-pole busbar support			WH-BSC/3P	79.70
Support end cover			WH-BSEC	21.85
Busbar hole inserts				
	M8 thread	14mm bar hole	SI-BHI/M8	1.30
	M10 thread	14mm bar hole	SI-BHI/M10	1.30
	M12 thread	14mm bar hole	SI-BHI/M12	1.30
	M16 thread	14mm bar hole	SI-BHI/M16	1.95



SL00-3X3/100F/HA

### Vertical fuse disconnects 100mm busbar mount - 3 pole individual pole switching

Size	For Fuses	Current Rating (A)	Switch Width (mm)	Busbar centre spacing (mm)	Part No.	\$NZ
DIN00	DIN000 & DIN 00	160	50	100	SL00-3X/100F/HA	217.85

### Vertical fuse disconnects 100mm busbar mount - 3 pole switching in one action

Size	For Fuses	Current Rating (A)	Switch Width (mm)	Busbar centre spacing (mm)	Part No.	\$NZ
DIN00	DIN000 & DIN 00	160	50	100	SL00-3X3/100F/HA	217.85

### 3 pole horizontal fuse-disconnects - 100mm centres busbar mount

Size	For Fuses	Current Rating (A)	Cable Connection	Connection Capacity(mm <sup>2</sup> )	Connection to Busbars	Part No.	\$NZ
DIN1	DIN1	250	Bottom	max. 150	Screw connection to busbars	LTL1-3/9/100AU	490.20
DIN2	DIN2	400	Bottom	max. 240	Screw connection to busbars	LTL2-3/9/100AU	724.35
DIN3	DIN2 & DIN3	630	Bottom	max. 300	Screw connection to busbars	LTL3-3/9/100AU	807.00

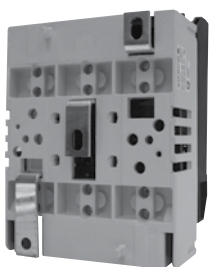

LTL1-3/9/100AU

Accessories	Technical Data	Dimensions
	68, 69, 70, 71, 73	80, 92, 93, 95



## 185mm busbar system

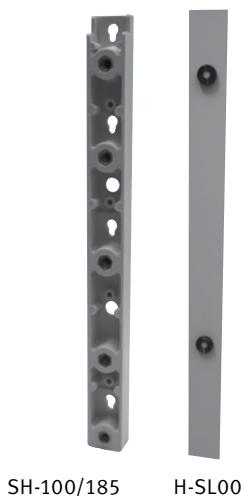

SH-100/185

H-SL00

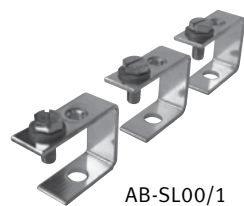

AB-SL00/1



AL-SL00/42

H-RF

### Description

Part No.

\$NZ

### 3 pole busbar support

For busbars at 100mm or 185mm spacing

SH100/185

55.95

### Busbar hole inserts

	Thread	Bar hole	Part No.	Price
	M8	14mm	SL-BHI/M8	1.30
	M10	14mm	SL-BHI/M10	1.30
	M12	14mm	SL-BHI/M12	1.30
	M16	18mm	SL-BHI/M16	1.95

### Adaptor kit (set of 3 pieces)

To mount 1x SL00-\*\*\* with front flush with SL 1,2,3

AB-SL00/1

93.10

### Adaptor plates

To mount 2x SL00-\*\* with fronts flush with SL 1,2,3

AL-SL00/42

77.15

Cover 50mm width for spare position on AL-SL00/42

H-SL00

32.10

### Spare position cover

Clip on cover 100mm width

H-RF

36.10

### Cover holder

Set of 4 blocks to mount onto SL00,1,2,3

AH-SL

21.75

## 185mm Rack systems

Jean Müller NZ Ltd assembles complete busbar rack assemblies to customer requirements. The racks listed below are stock types but we can build racks to suit all requirements.

Rack construction:

- SH100/185 type tested busbar supports
- Plated copper busbars with M12 inserts fitted and stainless steel bolt, spring washer and flat washer attached.
- a 3mm plastic backplate give complete finger protection when disconnects are fitted in all positions.



JMTE-BBS3



JMTE-BBS6 front,  
with 2x JMTE-Bar1  
fitted



JMTE-BBS6 rear,  
with 2x JMTE-BAR1  
fitted

Description	Part No.	\$NZ
-------------	----------	------

JMTE Rack systems				
700A	50x6mm bar	3 way	JMTE-BBS3	412.85
700A	50x6mm bar	4 way	JMTE-BBS4	462.80
700A	50x6mm bar	5 way	JMTE-BBS5	538.70
700A	50x6mm bar	6 way	JMTE-BBS6	618.80
1000A	60x10mm bar	4 way	JMTE-BBS4/1000	557.50
1000A	60x10mm bar	6 way	JMTE-BBS6/1000	745.50
1000A	60x10mm bar	8 way	JMTE-BBS8/1000	1,065.00
1300A	80x10mm bar	4 way	JMTE-BBS4/1300	643.00
1300A	80x10mm bar	6 way	JMTE-BBS6/1300	865.00
1300A	80x10mm bar	8 way	JMTE-BBS8/1300	1,238.00

Mounting straps			
For 6 way racks	30 x 5mm	JMTE-BAR1	29.75
For 6 way racks	50 x 5mm	JMTE-BAR2	37.25



**Earth and neutral bars**

Below is a listing of standard earth and neutral bars manufactured by Jean Müller NZ Ltd.

We also assemble any type and size to customer requirements. Bars are tin plated copper and fitted with standoff insulators. Connections shown are the quantity of busbar inserts fitted with screws and washers.



JMTE-ENBS



E/N bars

**Standard earth and neutral bars**

Connections	Bar Size	Current Rating	Part No.	\$NZ
8 x M10 connections	100x6x450mm	1200amp	JMTE-ENBS	234.40
8 x M12 connections				
6 x M10 connections	50x6x800mm	700amp	JMTE-ENBS2	234.40
8 x M12 connections				
10 x M12 connections	50x6x810mm	700amp	JMTE-ENBS10	168.10

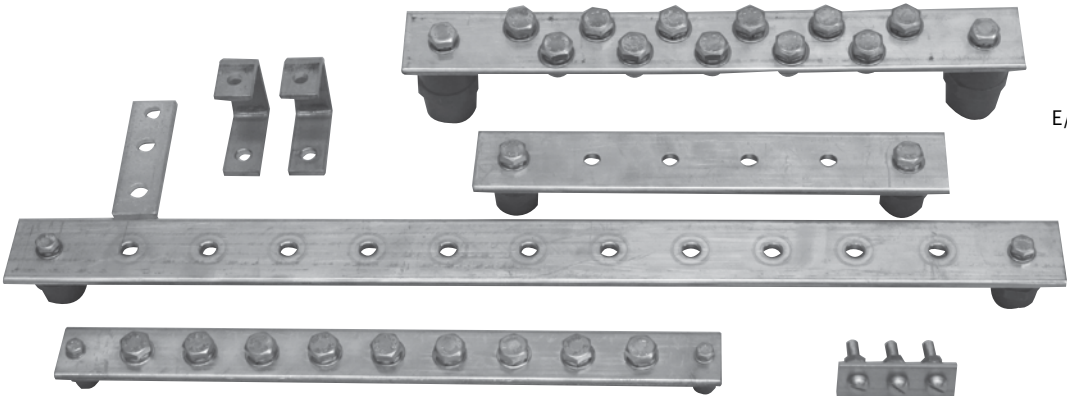

E/N bars made to customer specification



## *Distribution cabinets series KVS*



### **Range**

- 850mm high cabinets
- four widths from 4 way to 10 way
- available in kitset or assembled
- available with busbars up to 1000A

### **Construction**

- constructed from glass-fibre reinforced polyester to DIN14598
- cabinet and base are separate items

### **Features**

- IP44 protection
- three point door locking
- ribbed surface to resist poster adhesion
- door opening 180°
- grid for additional ground holding available



## Distribution cabinets series KVS 850mm height

Cabinet supplied as kitset

	No of ways	Dimensions mm	Part No.	\$NZ
	4 way	862 x 462 x 327	KVS00/10SV	935.70
	5 way	862 x 596 x 327	KVS0/10SV	1,052.50
	6 way	862 x 791 x 327	KVS1/10SV	1,195.00
	7 way	862 x 1121 x 327	KVS2/10SV	1,493.50

Cabinet supplied assembled

	No of ways	Dimensions mm	Part No.	\$NZ
	4 way	862 x 462 x 327	KVS00/10	1,028.35
	5 way	862 x 596 x 327	KVS0/10	1,156.70
	6 way	862 x 791 x 327	KVS1/10	1,318.75
	7 way	862 x 1121 x 327	KVS2/10	1,641.00

Cabinet supplied assembled with 700A busbars and keylock

	No of ways	Dimensions mm	Part No.	\$NZ
	4 way	862 x 462 x 327	KVS00/10SAP	1,364.15
	5 way	862 x 596 x 327	KVS0/10SAP	1,530.30
	6 way	862 x 791 x 327	KVS1/10SAP	1,827.30
	7 way	862 x 1121 x 327	KVS2/10SAP	2,324.50

## *Distribution cabinets series NKVS*



### **Range**

- 1100mm high cabinets
- three widths from 4 way to 8 way
- available with busbars up to 1000A

### **Construction**

- constructed from glass-fibre reinforced polyester to DIN14598
- cabinet and base are separate items

### **Features**

- IP44 protection
- three point door locking
- door opening 180°
- grid for additional ground holding available

## Distribution cabinets series NKVS 1100mm height

Cabinet supplied assembled

	No of ways	Dimensions mm	Part No.	\$NZ
	4 way	1100 x 596 x 327	NKVS0	1,504.65
	6 way	1100 x 785 x 327	NKVS1	1,733.00
	8 way	1100 x 1115 x 327	NKVS2	2,230.00

Cabinet supplied assembled with 700A busbars and keylock

	No of ways	Dimensions mm	Part No.	\$NZ
	4 way	1100 x 596 x 327	NKVS0/SAP	1,834.25
	6 way	1100 x 785 x 327	NKVS1/SAP	2,154.70
	8 way	1100 x 1115 x 327	NKVS2/SAP	2,801.00





## Distribution cabinets - bases and accessories

### Bases for KVS and NKVS cabinets in kitset form



For cabinets	Dimensions mm	Part No.	\$NZ
KVS00	902 x 460 x 310	FPO0	528.30
KVS0 & NKVS0	902 x 585 x 310	FPO	531.00
KVS1 & NKVS1	902 x 780 x 310	FP1	615.25
KVS2 & NKVS2	902 x 1110 x 310	FP2	740.60

### Bases for KVS and NKVS cabinets assembled with 700A E/N bar



No. of ways	Dimensions mm	Part No.	\$NZ
KVS00	902 x 460 x 310	FP00/SAN	638.35
KVS0 & NKVS0	902 x 585 x 310	FP0/SAN	683.80
KVS1 & NKVS1	902 x 780 x 310	FP1/SAN	789.15
KVS2 & NKVS2	902 x 1110 x 310	FP2/SAN	974.90

### Accessories

	Part No.	\$NZ
Cylinder key lock for KVS & NKVS cabinets	CKL-NKVS	59.00
Additional charge for lock keyed to customers requirement (net price)	CKL-SOP	46.00
Grid baseplate to increase groundholding	GBPLO	163.70
Padlockable handle	SV-PL	136.25



## Distribution cabinets series EH

### Empty cabinets

Model	Dimensions mm	Part No.	\$NZ
EHFB	1349 x 425 x 240	EHFB	797.00
EHFERB	1622 x 425 x 240	EHFERB	972.40

### Fitted cabinets

Model	Fitted with	Dimensions mm	Part No.	\$NZ
EHFB	- formica panel 400 x 450mm - key lock	1349 x 425 x 240	EHFB/PNL	972.00
EHFERB	- 700A phase bars - single earth/neutral bar - key lock	1622 x 425 x 240	EHFERB/35	1,395.00

### Accessories

	Part No.	\$NZ
Cylinder key lock for EH cabinets	CKL-EH	59.00
Additional charge for lock keyed to customers requirement (net price)	CKL-SOP	46.00
Threaded insert M6	SOC-IT6	2.55



EHFB



EHFERB



EHFERB/35 with disconnects fitted



## Universal measuring devices



UMG96L



UMG96S

	Part No.	\$NZ
3 phase display indicating:	UMG96L	542.20
- voltage, L-L, L-N, max values, min values		
- current L1, L2, L3, N, average, max, MDI		
- frequency and power factor		
- real power, W per phase, sum & max		
- apparent power, VA per phase, sum & max		
- reactive power, VAR per phase, sum & max		
- energy kWh total and kVARh total		

	Part No.	\$NZ
3 phase display indicating:	UMG96S	1,362.10
- voltage, L-L, L-N, max values, min values		
- current L1, L2, L3, N, average, max, MDI		
- frequency and power factor		
- real power, W per phase, sum & max		
- apparent power, VA per phase, sum & max		
- reactive power, VAR per phase, sum & max		
- energy kWh total and kVARh total		
- total harmonic distortion		
- 2x digital outputs		
- RS485 interface		
- RS232 interface		
- data memory		

### MDI metering - complete solutions



3 Phase metering using UMG 96L meter	Part No.	\$NZ
The following three items are all that is needed to construct a fully metered vertical disconnect. Displayed functions are as shown for the UMG96L on the facing page.		
Vertical disconnect from page 23	SL*-3X*/W/3A	
Current transformers from page 23 (3x reqd)	WKD51/1/***-5	
UMG96L mounted in an IP65 enclosure Enclosure dimensions 130 x 130 x 100mm A bracket on the enclosure provides easy mounting on the top of the disconnect. The meter is fully wired for connection to the CTs and to the three phase supply and neutral. The phase connections are wired through 5A fuses.	UMG96L/ENCL	697.20



## *ENSTO - Saves your energy*



Ensto Underground offers a comprehensive solution for 1-36kV cable networks.

The products have been developed to endure the most varying and demanding conditions and both their mechanical and electrical properties have been thoroughly type tested. Ensto products exceed the requirements of international and national standards.

The shear bolt connector and cable lug range stocked by Jean Müller NZ Ltd offer many advantages over other brands available including:

- both LV and MV lugs available
- wider range of LV connectors and lugs
- less tools required
- competitive pricing.





## Low voltage cable connectors & lugs 1kV

### Shear head bolt connectors with barrier 1kV



ESLJ

Nominal cable size	No. of bolts	Tools required for installation	Part No.	\$NZ
Suitable for solid and stranded, sector and circular shaped cables				
6-50mm <sup>2</sup>	2	14mm Socket	ESLJ6-50	10.85
35-95mm <sup>2</sup>	2	14mm Socket	ESLJ35-95	12.15
95-240mm <sup>2</sup>	4	21mm Socket	ESLJ95-240	25.95
150-300mm <sup>2</sup>	4	21mm Socket	ESLJ150-300	48.45

### Fillers



ESLJT

Nominal cable size	Part No.	\$NZ
Used with ESLJ connectors when the cable to be joined is smaller		
16-35mm <sup>2</sup> for ESLJ35-95	SLJT2	2.60
50-70mm <sup>2</sup> for ESLJ95-240	SLJT3	2.60
95-120mm <sup>2</sup> for ESLJ150-300	SLJT4	2.60

### Shear head bolt cable lugs 1kV



ESAL

Nominal cable size	No. of bolts	Tools required for installation	Part No.	\$NZ
Suitable for solid and stranded, sector and circular shaped cables				
6-50mm <sup>2</sup>	2	14mm Socket	ESAL6-50	19.45
50-95mm <sup>2</sup>	2	14mm Socket	ESAL50-95	21.90
95-185mm <sup>2</sup>	2	21mm Socket	ESAL95-185	31.15
150-300mm <sup>2</sup>	2	24mm Socket	ESAL150-300	



## Medium voltage cable connectors & lugs 36kV



### Shear head bolt connectors with barrier 1kV



ESMJ

Nominal cable size	No. of bolts	Tools required for installation	Part No.	\$NZ
Suitable for solid and stranded, sector and circular shaped cables				
10-95mm <sup>2</sup>	4	17mm Socket	ESMJ10-95	19.10
95-240mm <sup>2</sup>	4	17mm Socket	ESMJ95-240	43.85



ESML

### Shear head bolt connectors with barrier 1kV

Nominal cable size	No. of bolts	Tools required for installation	Part No.	\$NZ
With 13mm palm hole				
10-95mm <sup>2</sup>	2	17mm Socket	ESML10-95	26.85
95-240mm <sup>2</sup>	2	24mm Socket	ESML95-240	49.35



## Low voltage heat shrink products

### Thick wall heat shrink tubes

Diameter max/min	Diameter max/min	Final wall thickness	Part No.	\$NZ
Black with adhesive, UV resistant, halogen free, 1m length.				
19/6 mm		2.4 mm	ECPL19-6	18.55
33/8 mm		3.0 mm	ECPL33-8	23.20
51/16 mm		2.1 mm	ECPL51-16	41.20
68/22 mm		4.1 mm	ECPL68-22	51.05
85/25 mm		4.1 mm	ECPL85-25	61.50



ESBO

### Cable break outs

Diameter max/min	Diameter max/min	Final wall thickness	Part No.	\$NZ
Black with adhesive, UV resistant, halogen free				
38/14 mm	15/4 mm	1.5 mm	ESBO3-14/4	9.80
48/14 mm	15/4 mm	1.5 mm	ESBO4-14/4	10.70
55/25 mm	20/6 mm	3.0 mm	ESBO4-25/6	16.75
72/22 mm	25/9 mm	3.0 mm	ESBO4-22/9	19.05
100/33 mm	35/14 mm	3.0 mm	ESBO4-33/14	24.80



ESEC

### Cable end caps

Diameter max/min	Final wall thickness	Part No.	\$NZ
Black with adhesive, UV resistant, halogen free			
40/15 mm	3.2 mm	ESEC40/15	4.35
63/24 mm	3.7 mm	ESEC63/24	7.55
75/32 mm	4.3 mm	ESEC75/32	10.40



## Current transformers

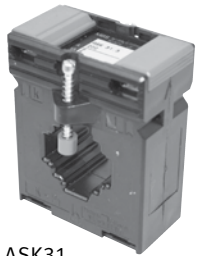

ASK31

Max size of primary conductor (mm)		Primary current	Secondary current (A)	VA	Part No.	\$NZ
Bar	Cable Dia					
Foot or busbar mount Class 1 accuracy						
30 x 10mm	26mm	200A	5A	5VA	ASK31.3/200/5	46.80
30 x 10mm	26mm	400A	5A	5VA	ASK31.3/400/5	46.80
30 x 10mm	26mm	600A	5A	5VA	ASK31.3/600/5	46.80



ASK51

50 x 12mm	44mm	800A	5A	10VA	ASK51.4/800/5	63.40
50 x 12mm	44mm	1000A	5A	10VA	ASK51.4/1000/5	63.40
50 x 12mm	44mm	1200A	5A	10VA	ASK51.4/1200/5	63.40



ASK101

100 x 10mm	70mm	600A	5A	10VA	ASK101.4/600/5	139.05
100 x 10mm	70mm	800A	5A	10VA	ASK101.4/800/5	139.05
100 x 10mm	70mm	1000A	5A	10VA	ASK101.4/1000/5	139.05
100 x 10mm	70mm	1200A	5A	10VA	ASK101.4/1200/5	139.05
100 x 10mm	70mm	1500A	5A	10VA	ASK101.4/1500/5	139.05



ASK128

128 x 38mm	-	1000A	5A	10VA	ASK128.4/1000/5	243.15
128 x 38mm	-	1200A	5A	10VA	ASK128.4/1200/5	243.15
128 x 38mm	-	1500A	5A	15VA	ASK128.4/1500/5	243.15
128 x 38mm	-	2000A	5A	15VA	ASK128.4/2000/5	243.15
128 x 38mm	-	2500A	5A	15VA	ASK128.4/2500/5	243.15

### Power distribution blocks



Incoming cables		Outgoing cables		Part No.	\$NZ
Qty	Size (mm <sup>2</sup> )	Qty	Size (mm <sup>2</sup> )		
A space saving and cost saving alternative to DIN-Rail mount terminals. Panel or DIN-Rail mounting IP20 finger proof terminals Plated brass block accepts aluminium or copper cables					
3	2.5- 16	4	2.5- 16	FTG-1/080	24.60
1	10 - 35	6	2.5- 16	FTG-1/125	58.50
		1	6 - 16		
1	35 - 120	5	2.5- 16	FTG-1/250	97.75
2	6 - 35	4	2.5- 10		

### Standoff insulators



Stand off height (mm)	Fixing thread	Part No.	\$NZ
Colour - red			
25	M6	DB25/PM6	7.70
34	M8	DB34/PM8	7.70
34	M10	DB34/PM10	7.70
50	M10	DB50/PM10	10.25
65	M10	DB65/PM10	11.95



## TECHNICAL INFORMATION

		<i>Page</i>
JEAN MÜLLER	<i>Fuses</i>	<i>62</i>
	<i>Vertical disconnect</i>	<i>68</i>
	<i>Horizontal disconnect</i>	<i>70</i>
	<i>Busbar system</i>	<i>73</i>
MBS	<i>Current transformers</i>	<i>74</i>
FTG	<i>Power distribution blocks</i>	<i>74</i>

## HRC DIN fuses

Type	Standard DIN and Striker Fuses	Semiconductor Fuses	Motor Rated Fuses	CT Mount Fuses	D-Type Fuses	Cylindrical House Service Fuses
<b>Reference</b>	SM...-GL/... SM...-GL/...K	SM...-UF/...	SM...-AM/...	SMCT...-GL/...	GLD...-	SKR...
<b>Utilisation</b>	Cable and Line protection	Semiconductor protection	Motor protection	Cable and Line protection	Cable and Line protection	Cable and Line protection
<b>Protection Type</b>	Full Range	Short Circuit only	Short Circuit only	Full Range	Full Range	Full Range
<b>Characteristic</b>	gL/gG	aR	aM	gL/gG	gL/gG	gL/gG
<b>Rated Voltage</b>	500 VAC	660 VAC	500 VAC	400 VAC	500 VAC	690 VAC (100A 500V) (125A 400V)
<b>Maximum Voltage</b>	550 VAC 484 VDC	690 VAC 550 VDC	550 VAC 484 VDC			
<b>Rated Breaking Capacity</b>						
at 500 VAC	120 kA	100 kA	120 kA	50 kA	50 kA	
at 220/440 VDC	25 kA		25 kA			
<b>Construction</b>						
Body		Steatite			-	-
Blade Contacts		Silver Plated Copper Alloy			-	-
Fuse Element		Silver Plated Strip			-	-
<b>Fuse Blown Indication</b>		Flap indicator			None	None

### Notes :

#### Characteristics/Standards

gL	VDE0636
gG	IEC269
aR	VDE0636 Part 23, IEC269 Part 4
aM	VDE0636 Part 2011, IEC 269



### Fuses for motor protection

1. Fuses with aM characteristic

The rated fuse current must be  $\geq$  rated motor current.

2. Fuses with gL/gG characteristic

The following table shows fuse ratings for short circuit protection of 3 phase motors, 1500 rpm and internal or surface cooling

Direct Starting : max start current 6 x rated motor current, max start time 5 seconds

Star/Delta Starting : max start current 2 x rated motor current, max start time 15 seconds

Ratings for Star/Delta starting also apply for 3 phase slip-ring motors

kW	Motor Rating @ 400V			Fuse Rating aM (Amps)		Fuse Rating gL/gG (Amps)	
	cos $\phi$	Eff %	Rated Motor Current Amps	D.O.L Start	D.O.L Start	Star-Delta Start	
0.18	0.7	62	0.64	2	2	-	
0.25	0.7	62	0.8	2	4	2	
0.55	0.75	69	1.6	2	4	2	
0.75	0.8	74	2	4	6	2	
1.1	0.83	77	2.6	4	6	4	
2.2	0.83	81	5	6	10	6	
3.0	0.84	81	6.6	10	16	10	
4.0	0.84	82	8.5	10	20	10	
7.5	0.86	85	15.5	16	32	16	
11	0.87	87	22.5	25	40	25	
15	0.86	87	30	32	63	32	
22	0.87	89	43	50	80	50	
30	0.87	90	58	63	100	63	
37	0.87	90	72	80	125	80	
55	0.88	91	104	125	200	125	
75	0.88	91	142	160	200	160	
90	0.88	92	169	200	250	200	
110	0.88	92	204	250	315	200	
132	0.88	92	243	250	400	250	
160	0.88	93	292	315	400	315	
200	0.88	93	368	400	500	400	



# HRC DIN fuses

## Time/Current characteristics gL curve

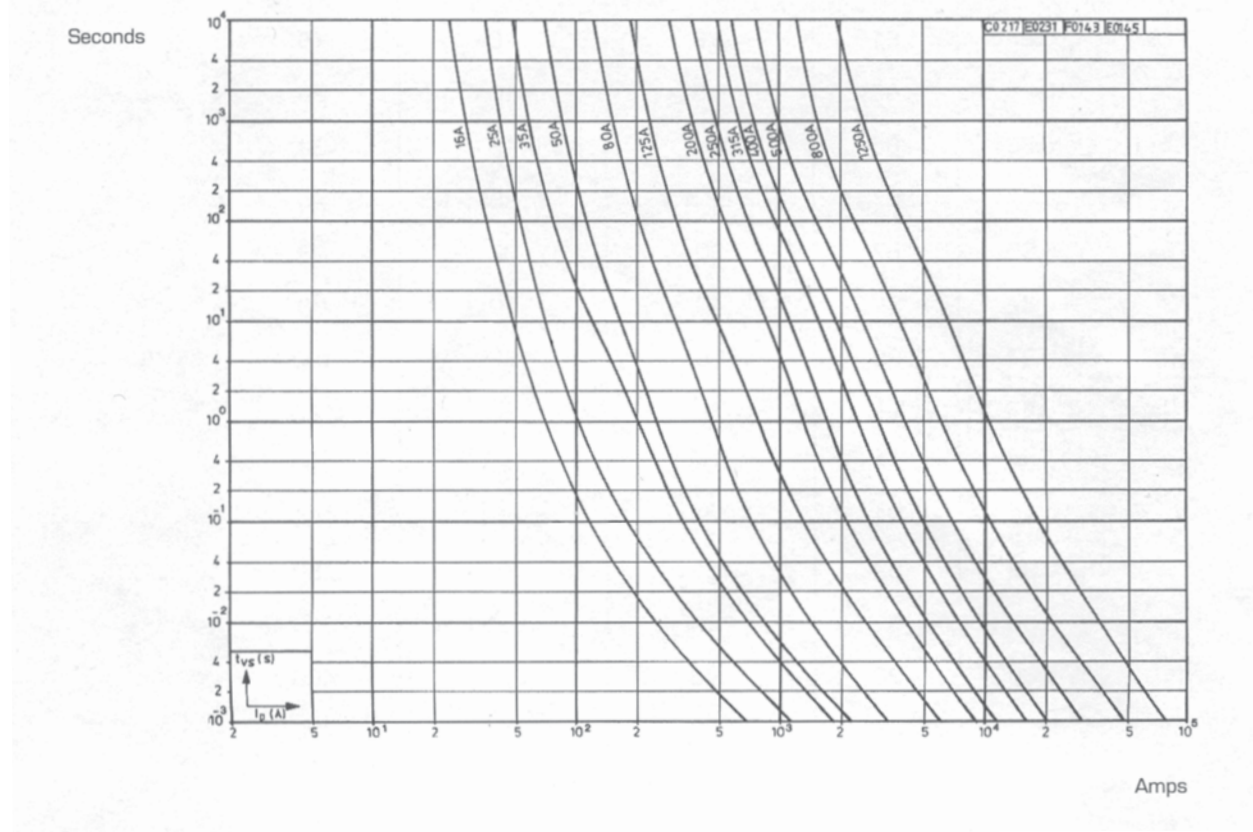
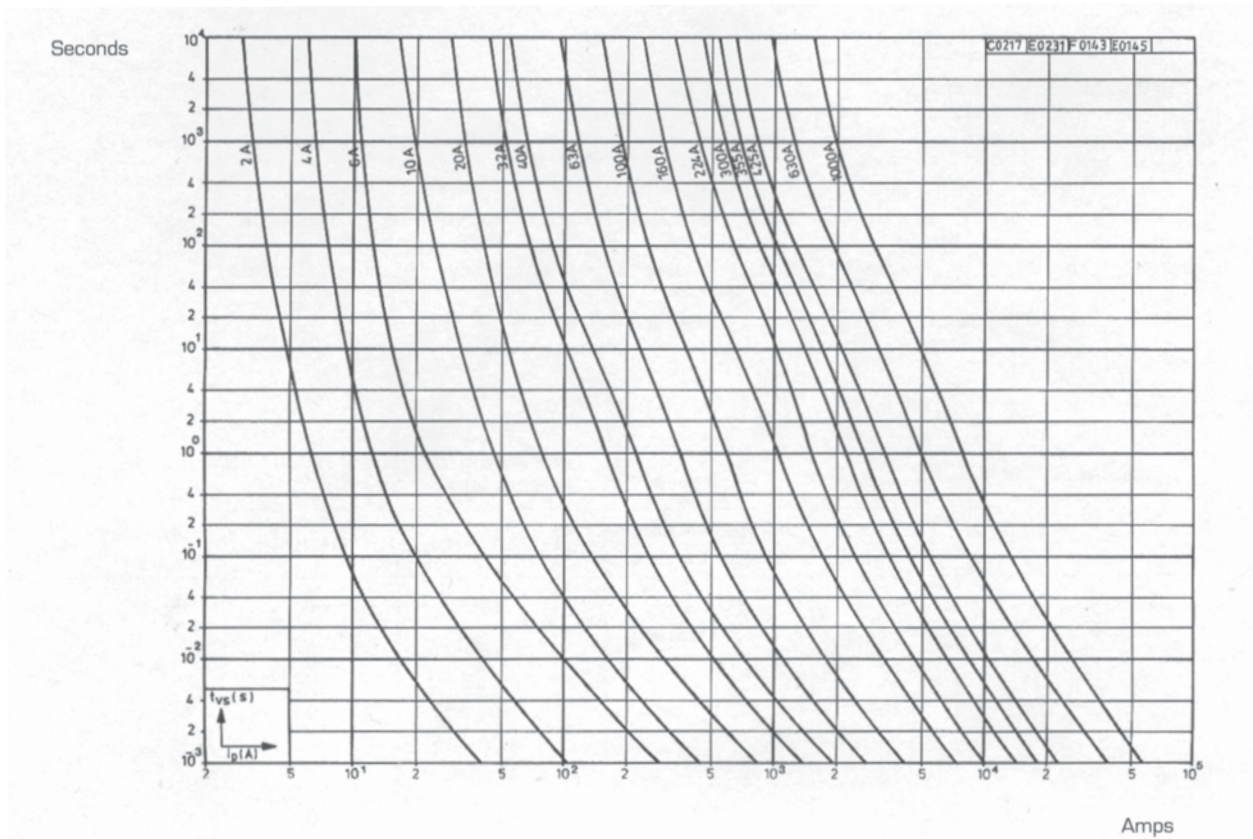

**Time/Current characteristics aM curve**

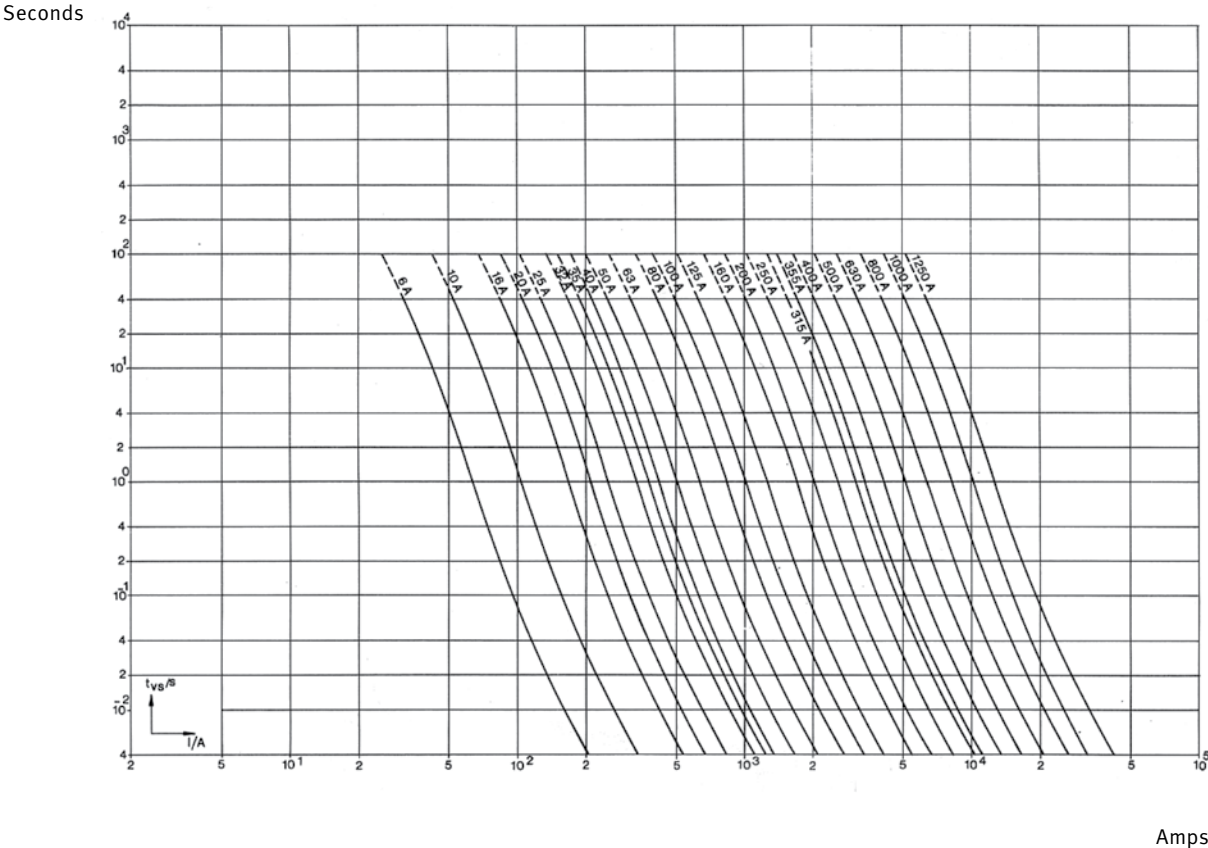



# HRC DIN fuses

Time/ Current characteristics of 1 curve

16A-400A

Seconds

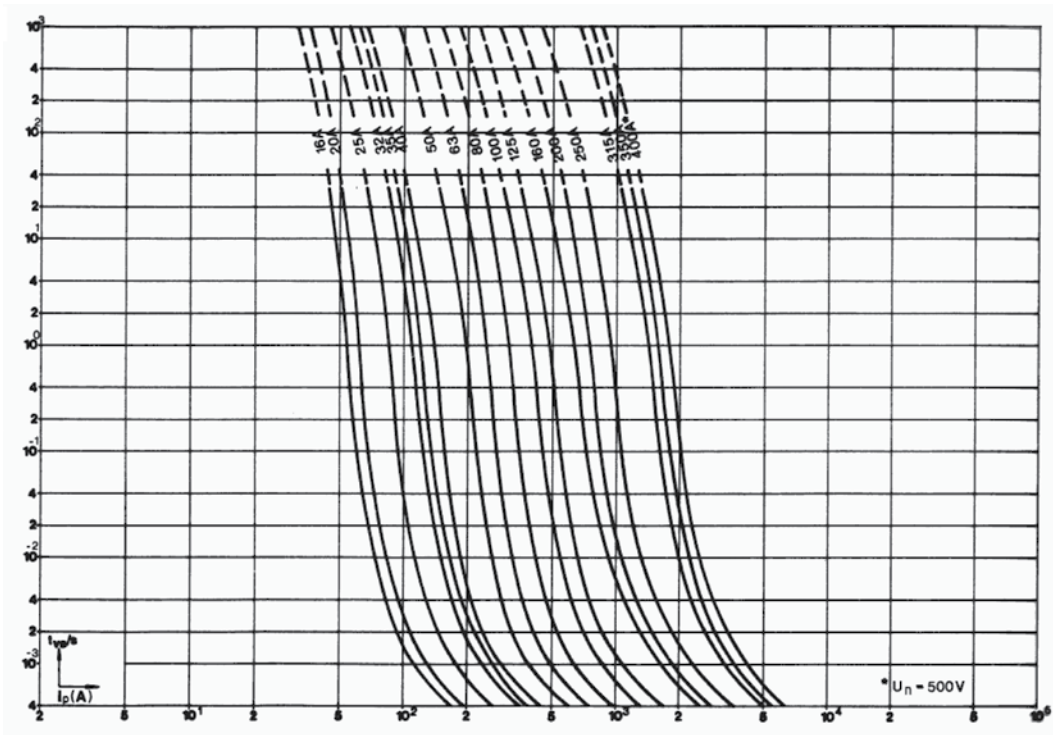

160-630A

Amps

Seconds

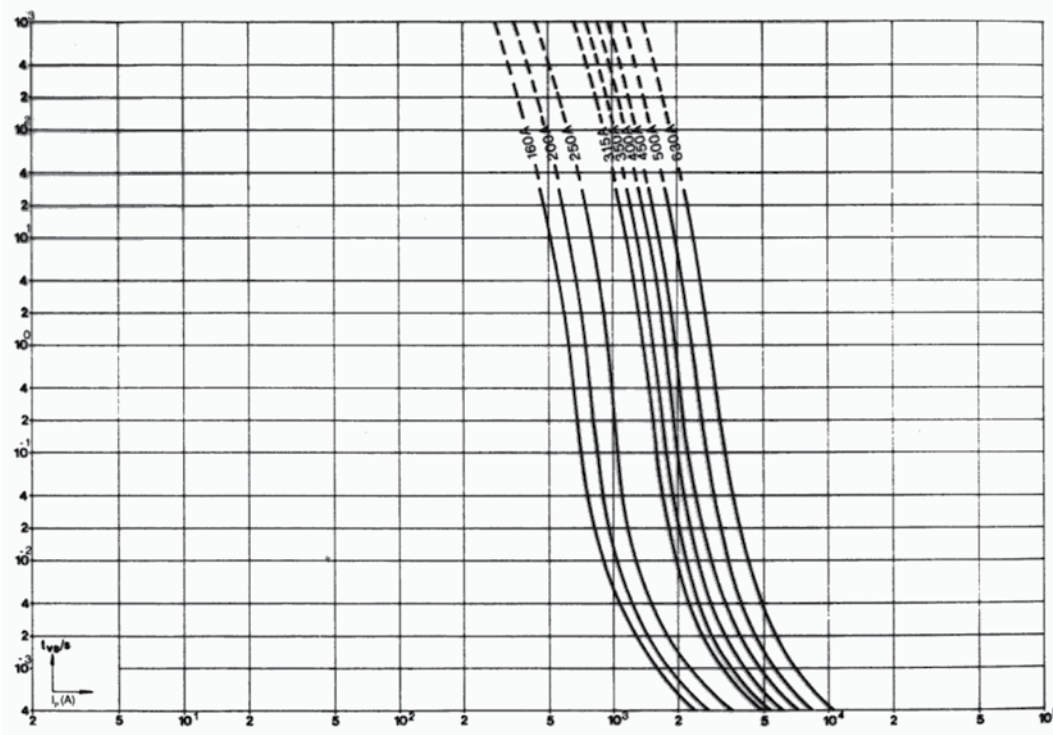

Amps

I<sup>2</sup>T values - gL curve

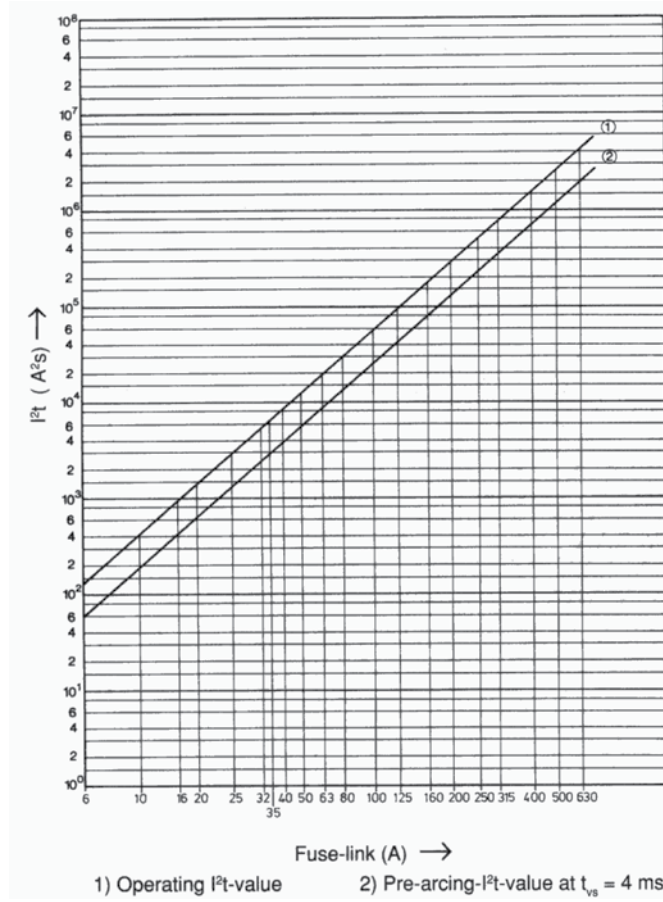

I<sup>2</sup>t values - aM curve

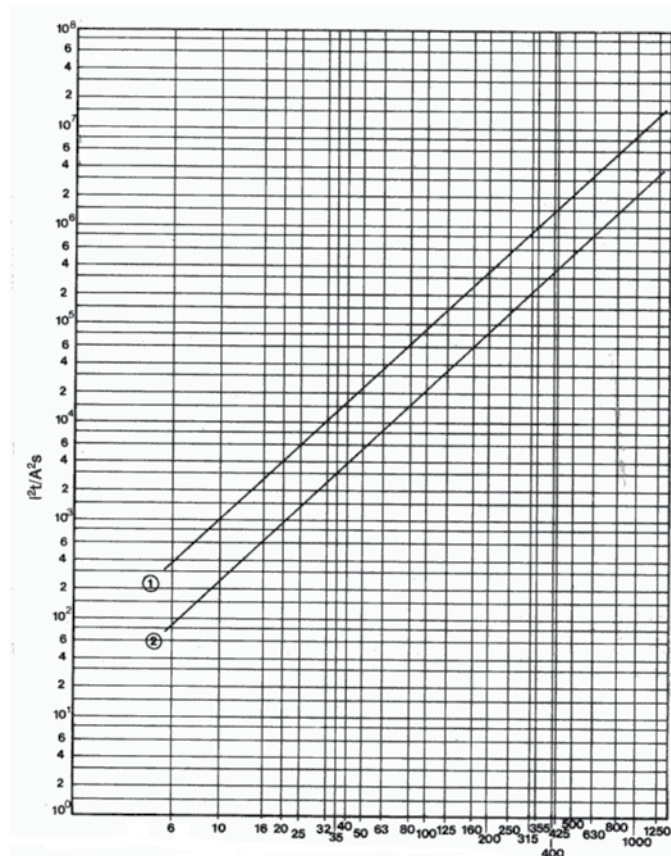

## Vertical disconnects

Type			SL00-3X3/ 100FHA	SL00-3X SL00-3X3	SL1G-3X/3A SL1G-3X3/3A SL1G-../W/HA	SL2G-3X/3A SL2G-3X3/3A SL2G-../W/HA	SL3-3X/3A SL3-3X3/3A SL3-../W/HA
<b>Electrical characteristics</b>							
Rated Voltage	U	[V]	500	500	500	500	500
Rated Current	/	[A]	160	160	250	400	630
Current (with Fuse links)	/	[A]	160	160	250	400	630
Current (with Solid links)	/	[A]	160	210 with TM00	400 with TM2	400 with TM2	800 with TM3-1250
Rated Frequency		[Hz]	40-60	40-60	40-60	40-60	40-60
Rated Insulation Voltage	U	[V]	800	750	1000	1000	1000
Rated Short Circuit Current		[kA]	50	120kA(500V)	80	80	110kA(500V)
Switching Class (with solid links)			AC-22B	AC-22B AC23B(400V)	AC-22B	AC-22B	AC-22B AC23B(400V)
Rated Making Capacity		[A]	480	480	1200	1890	2400
Rated Breaking Capacity		[A]	480	480	1200	1890	1890
Rated Impulse Voltage	U	[kV]	8	8	12	12	12
Electrical Life		[No. of ops]	200	200	200	200	200
Total Power Dissipation (without fuse-links)	P	[W]	20	18	29	74	110
<b>Fuse links</b>							
DIN Size			000 & 00	000 & 00	1	1 & 2	1 & 2 & 3
Max. Rated Current (gL/gG)	/	[A]	160	160	250	400	630
Permissible Maximum Power Dissipation per fuse-links		[W]	12	12	32	45	48
<b>Mechanical characteristics</b>							
Mechanical Life		[No. of ops]	1700	1700	1400	1400	1000
Weight (without packing)	3 pole	[kg]		2.4	4.9	4.9	7.5
Busbar fitting Screw Size			M8	M8	M12	M12	M12
<b>Terminal capacity</b>							
Spade Terminal (Standard Supply)			M8x16	M8x16	M10x25	M12x30	M12x30
Cable lug		[mm <sup>2</sup> ]	1x10-95	1x10-95	1x25-150	1x25-240	1x25-300
Flat bar		[mm]	20x10	20x10	30x10	30x10	30x10
Torque		[Nm]	12-15	12-15	30-35	35-40	35-40
Prism Clamp [P0070]							
Cable Size (Al/Cu)		[mm <sup>2</sup> ]	10-70	10-70	-	-	-
Torque		[Nm]	2.6	2.6	-	-	-
<b>Degree of protection</b>							
Front, device fitted							
Operating condition			IP30	IP30	IP30	IP30	IP30
Front cover open			IP10	IP10	IP10	IP10	IP10
<b>Service conditions</b>							
Max. Ambient Temperature		[C]	-25... +55 (reduced operation at max)				
Rated Duty			Uninterrupted duty				
Operation			Manual dependent				
Mounting Position			Vertical or Horizontal				
Altitude		[m]	Up to 2000				
Pollution Degree			3	3	3	3	3
Overvoltage Category			III	III	III	III	IV

\*tested with LV-HRC fuse-links characteristics gG

Type			SL3-3X/1000/HA SL3-3X3/1000/HA SLT3-...	SL3-3X2/1250/HA SL3-3X6/1250/HA	SL3-3X2/2000/HA
<b>Electrical characteristics</b>					
Rated Voltage	U	[V]	500	500	400
Rated Current	/	[A]	1000	1250	1600
Current (with Fuse links)	/	[A]	630	1250	1600
Current (with Solid links)	/	[A]	1000(TM3-1250)	1600	2000
Rated Frequency		[Hz]	40-60	40-60	40-60
Rated Insulation Voltage	U	[V]	1000	500	500
Rated Short Circuit Current (conditional)*		[kA]	110kA	110kA	50kA
Switching Class (with solid links)			AC-22B	AC22B(500V)	AC22B(400V)
Rated Making Capacity		[A]	2400	-	-
Rated Breaking Capacity		[A]	2400	-	-
Rated Impulse Voltage	U	[kV]	12	-	-
Electrical Life		[No. of ops]	100	-	-
Total Power Dissipation (without TM)	P	[W]	275	215	375
<b>Fuse links</b>					
DIN Size			3	2 & 3	2 & 3
Max. Rated Current (gL/gG)	/	[A]	630	630	800
Permissible Maximum Power Dissipation per fuse-link		[W]	51	46	43
<b>Mechanical characteristics</b>					
Mechanical Life		[No. of ops]	800	-	-
Weight (without packing)	3 pole	[kg]	9	16	33
Busbar fitting Screw Size			M12	M12	M12
<b>Terminal capacity</b>					
Spade Terminal			2xM12x35	3xM12x35	4xM12x35
Cable lug		[mm <sup>2</sup> ]	2x25-300 or 3x120	3x300	4x300
Flat bar		[mm]	-	-	-
Torque		[Nm]	35-40	35-40	35-40
<b>Degree of protection</b>					
Front, device fitted					
Operating condition			IP30	IP30	IP30
Front cover open			IP10	IP10	IP10
<b>Service conditions</b>					
Max. Ambient Temperature		[C]	-25... +55 (reduced operation at max)		
Rated Duty			Uninterrupted duty		
Operation			Manual dependent		
Mounting Position			Vertical or Horizontal		
Altitude		[m]	Up to 2000		
Pollution Degree			3	3	3
Overtoltage Category			IV	IV	IV

\* tested with LV-HRC- fuse-links characteristics gG

## Horizontal disconnects

Type			DSL*.. 60/183	LTL000-3/9/ 60/F57/5	LTL000-3/9	LTL00-../9	LTL1-../9
<b>Electrical characteristics</b>							
Rated Voltage	U	[V]	400	500	500	500	500
Rated Current	/	[A]	63	100	100	160	250
Current (with Fuse links)	/	[A]	63	100	100	160	250
Current (with Solid links)	/	[A]	-	160 with TM00	160 with TM00	210 with TM00	325 with TM1
Rated Frequency		[Hz]	40-60	40-60	40-60	40-60	40-60
Rated Insulation Voltage	U	[V] AC	400	500	690	800	800
Rated Short Circuit Current		[kA]	50	50	63	50	50
Switching Class (with solid links)			AC-23B	AC-22B	AC-22B	AC-22B	AC-22B
Rated Making Capacity		[A]	630	300	300	480	750
Rated Breaking Capacity		[A]	630	300	300	480	750
Rated Impulse Voltage	U	[kV]	8	8	8	8	8
Electrical Life	[No. of ops]		300	300	300	200	200
Total Power Dissipation (without fuse-links)	P	[W]	8	11.5	6.9	6.9	12.9
<b>Fuse links</b>							
DIN Size			DO1, D02	000	000	000 & 00	1
Max. Rated Current (gL/gG)	/	[A]	63	100	100	160	250
Permissible Maximum Power Dissipation per fuse-links		[W]	5.5	12	9	12	23
<b>Mechanical Characteristics</b>							
Mechanical Life	[No. of ops]		1700	1700	-	1700	1400
Weight (without packing)	3 pole	[kg]	0.26	0.57	0.52	0.72	2.5
	2 pole	[kg]	-	-	-	0.7	2.14
	1 pole	[kg]	-	-	-	0.32	1.00
<b>Terminal capacity</b>							
Spade Terminal (Standard Supply)	[dia]		-	-	M8	M8	M10
Cable lug	[mm <sup>2</sup> ]		-	-	1x10-70	1x10-95	1x25-150
Flat bar	[mm]		-	-	-	20x10	30x10
Torque	[Nm]		-	-	12-15	12-15	30-35
Clamp Terminal							
Cable size (Al/Cu)	[mm <sup>2</sup> ]		1.5-25	1.5-25	6-50	1.5-70	25-150
Flat bar	[mm]		-	6x9	-	6x9	6x16
Torque	[Nm]		-	2.6	2.6	2.6	9.5
Prism Clamp							
Cable Size (Al/Cu)	[mm <sup>2</sup> ]		-	-	10-70	10-70	70-150
Torque	[Nm]		-	-	4.5	2.6	4.5
Double Prism Clamp							
Cable Size (Al/Cu)	[mm <sup>2</sup> ]		-	-	2x10-50	-	2x70-95
Torque	[Nm]		-	-	4.5	-	4.5
<b>Degree of protection</b>							
Front, device fitted							
Operating condition			IP20	IP20	IP20	IP20	IP20
Front cover open			IP10	IP10	IP10	IP10	IP10
<b>Service conditions</b>							
Max. Ambient Temperature	[C]		-25... +55 (reduced operation at max)				
Rated Duty			Uninterrupted duty				
Operation			Manual dependent				
Mounting Position			Vertical or Horizontal				
Altitude	[m]		Up to 2000				
Pollution Degree			3	3	3	3	3
Overvoltage Category			III	III	III	III	III



Type			LTL2-.../9	LTL3-.../9	LTL4A-.../1250/9	LTL4A-.../1600/9
<b>Electrical characteristics</b>						
Rated Voltage	U	[V]	500	500	500	500
Rated Current	/	[A]	400	630	1250	1600
Current (with Fuse links)	/	[A]	400	630	1250	1600
Current (with Solid links)	/	[A]	520 with TM2	1000 with TM3ISM	1250	1600
Rated Frequency		[Hz]	40-60	40-60	40-60	40-60
Rated Insulation Voltage	U	[V]	800	800	800	800
Rated Short Circuit Current		[kA]	80	80	80	80
Switching Class (with solid links)			AC-22B	AC-22B	AC-22B	AC-22B
Rated Making Capacity		[A]	1200	1890	3750	2400
Rated Breaking Capacity		[A]	1200	1890	3750	2400
Rated Impulse Voltage	U	[kV]	8	8	8	8
Electrical Life		[No. of ops]	200	200	100	100
Total Power Dissipation (without fuse-links)	P	[W]	27	52	32	52
<b>Fuse links</b>						
DIN Size			2	2 & 3	4A	4A
Max. Rated Current (gL/gG)	/	[A]	400	630	1250	1600
Permissible Maximum Power Dissipation per fuse-links		[W]	34	48	110	164
<b>Mechanical characteristics</b>						
Mechanical Life		[No. of ops]	800	800	500	500
Weight (without packing)	3 pole	[kg]	3.1	4.8	15.7	15.7
	2 pole	[kg]	-	3.0	-	-
	1 pole	[kg]	-	1.5	5.3	5.3
<b>Terminal capacity</b>						
Spade Terminal (Standard Supply)		[dia]	M10	M10	M16	2 x M12
Cable lug		[mm <sup>2</sup> ]	1x25-240	1x25-300	400	-
Flat bar		[mm]	30x10	40x10	80x30	80x30
Torque		[Nm]	30-35	30-35	50-60	35-40
Clamp Terminal						
Cable size (Al/Cu)		[mm <sup>2</sup> ]	25-240	-	2x(95-300)	-
Flat bar		[mm]	10x16	11x21	-	-
Torque		[Nm]	23	23	-	-
Prism Clamp						
Cable Size (Al/Cu)		[mm <sup>2</sup> ]	120-240	120-300	-	-
Torque		[Nm]	11	11	-	-
Double Prism Clamp						
Cable Size (Al/Cu)		[mm <sup>2</sup> ]	2x120-150	2x120-240	-	-
Torque		[Nm]	11	11	-	-
<b>Degree of protection</b>						
Front, device fitted						
Operating condition			IP20	IP20	IP20	IP20
Front cover open			IP10	IP10	IP10	IP10
<b>Service conditions</b>						
Max. Ambient Temperature		[°C]	-25... +55 (reduced operation at max)			
Rated Duty			Uninterrupted duty			
Operation			Manual dependent			
Mounting Position			Vertical or Horizontal		Vertical	Vertical
Altitude		[m]	Up to 2000			
Pollution Degree			3	3	3	3
Overvoltage Category			III	III	IV	IV

## Horizontal disconnects accessories/fuse base

Accessories - Micro switches			
Switch Position Indicator Fuse Blown Position Indicator		EV-LT00, EV-LTL123-1 K-LTL**-1/H	EV-LTL123-3, EV-LTL4A K-LTL**-3/H, K-LTL4A
Rated Current @ 250V AC	A	5	8
Rated Current @ 110V DC	A	0.35	0.6
Electrical Life @ AC11	[ No. of Operations]	100,000	50,000

D - Type fuse bases
<ul style="list-style-type: none"> <li>- Rated Current: 25A and 63A</li> <li>- Rated Voltage: 25A - 500V, 63A - 690V</li> <li>- Standard: IEC269-3-1</li> <li>- Flame Resistance to: UL94V-ø</li> <li>- Terminal: Clamp Type, self lifting, 25mm<sup>2</sup> max.</li> <li>- Touch Protection: Clip-on Covers for top, bottom and sides are available.</li> <li>- Mounting: On Busbars 12-30mm width, 5 or 10mm thick.</li> </ul>

Terminal with connecting lug						
	AL/Cu Cable [mm <sup>2</sup> ]				Allen Key	Tightening Torque (Nm)
	Rounded Stranded	Sector Stranded	Round Solid	Sector Solid		
K2G/A	35-185	35-185	35-185	50-185	6 mm	40
KM2G/AF3040	25-300	25-240	25-150	25-240	6 mm	40
K2HG/2/AF30	2 x 25-120	2 x 35-120	2 x 25-50	2 x 50-120	6 mm	40
KV2HG/2/AF30	2 x 12-185	2 x 12-185	-	-	6 mm	40

Fuse switches DIN-Rail mount			
		WH-AMB1/10 WH-AMB3/10	WH-AMB1/22 WH-AMB3/22
Rated Current @ 690V AC @ 440V DC		32A 32A	125A 125A
Application Category		AC-22B (400V)	AC-20B (690V)
Conditional Rated Short Circuit Current		50kA (400V)	100kA (500V)
Terminal Capacity		1x 0.75 - 25mm <sup>2</sup> 2x 0.75 - 10mm <sup>2</sup>	1x 4 - 50mm <sup>2</sup>

## Busbar system components

Busbar supports	SST-60/3	WH-BSC/3P	SH-100/185
Busbar thickness	5 or 10 mm	10mm	any
Busbar width	20 or 30 mm	30-60mm	20-120mm
Busbar mounting	Clamp on 60mm centres	Clamp on 100mm centres	Bolted into threaded bush M10 on 100mm or 185mm centres
Material		Silicon free, chlorine free	Glass-fibre, reinforced polyester
Temperature withstand		120C	
Short-circuit withstand	See Graph	See Graph	See Graph

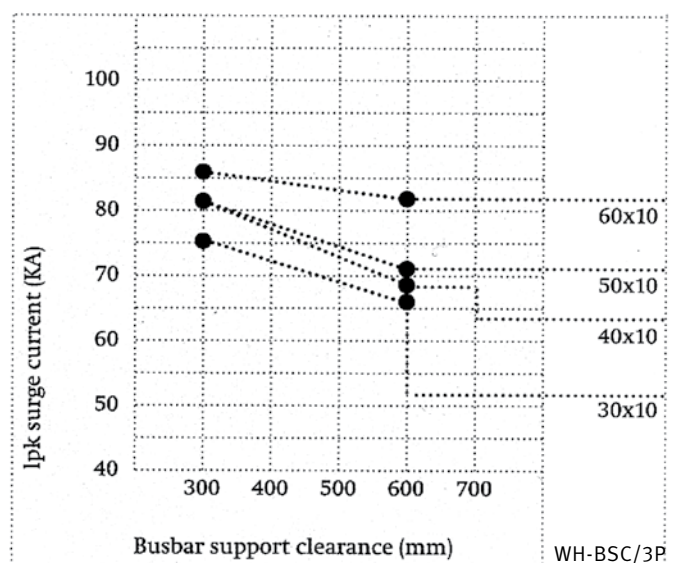
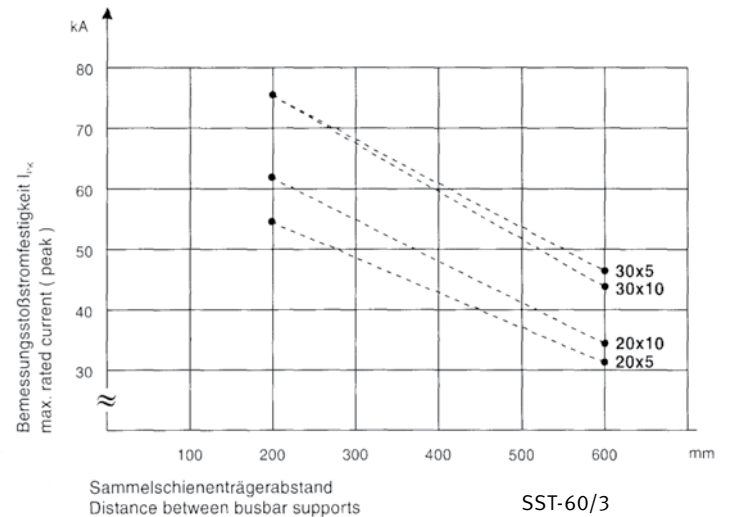
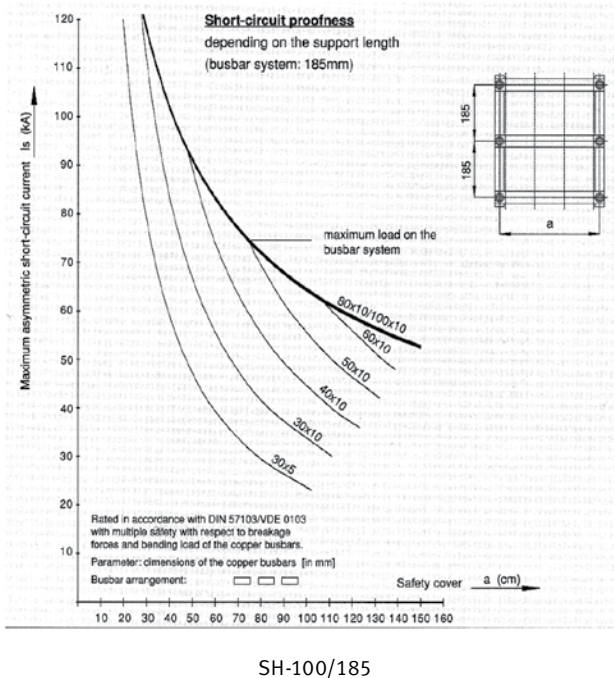



## Current transformers and standoff insulators

### Current transformers

Type	ASK**
Standards	VDO 414 Part 1; DIN42600; VBG4; IEC60044-1
Construction	
Case	Ultrasonically welded Polycarbonate
Flammability	Self-extinguishing to UL94Vo
Terminals	Nickel Plated Brass
Environment	For dry indoor use.
Temperature	-5 C to +40 C
Ratings	
Voltage maximum	0.72 kV
Frequency	50/60Hz
Nominal Thermal Short Time Current	60 x In
Insulation	Class E
Supply	
Foot Mountings	2
Bar Mount Screws	2 (12 with ASK128)

### Standoff insulators

Type		DB25	DB34	DB50	DB65
Operating Temperature		-40 C to +130 C			
Flammability		to UL94VO			
AC Internal Flashover Voltage	kV	20	30	40	40
AC Surface Flashover Voltage	kV	7	10	12	15
Twisting Stress	DN X m	3	5	6	6
Compressive Stress	DN	2100	6500	6800	8300
Cantilever Stress	DN	180	450	450	700
Tensile Stress	DN	300	800	850	1500

### Power distribution blocks

			FTG-1/080	FTG-1/125	FTG-1/250
Operational Voltage	VAC		600	600	600
Current Rating Cu/Al	A		85 / 66	130 / 103	300 / 260
Short Cct Peak - Ipk	kA		2.7	30	51
Short Cct 1 second - Icw	kA		1.9	4.4	21
Input connections	Qty / Size		1x 2.5-16mm <sup>2</sup>	1x 10-35mm <sup>2</sup>	1x 35-120mm <sup>2</sup>
	Tool		Pozi or flat screwdriver	4mm Allen Key	6mm AllenKey
	Torque	Nm	1.5	3.5	19
Output connections without ferrules	Qty / Size		2x 2.5-16mm <sup>2</sup> 4x 2.5-6mm <sup>2</sup>	1x 6-16mm <sup>2</sup> 6x 2.5-16mm <sup>2</sup>	4x 2.5-10mm <sup>2</sup> 5x 2.5-16mm <sup>2</sup> 2x 6-35mm <sup>2</sup>
	Tool		Pozi or flat screwdriver	Pozi or flat screwdriver	Flat screwdriver
	Torque	Nm	1.5 / 0.8	3.5 / 2.0	18 / 18 / 31
Mounting			DIN-Rail or base mounting with 2x M5 screws		
Protection			IP20	IP20	IP20
Dimensions (LxWxH) mm			66 x 27 x 47	74 x 27 x 47	96 x 45 x 49

## DIMENSIONS

		<i>Page</i>
JEAN MÜLLER	<i>Fuses and solid links</i>	76
	<i>D-Type fuses and bases</i>	79
	<i>Vertical disconnects</i>	80
	<i>Horizontal disconnects</i>	86
	<i>Busbar system components</i>	94
	<i>Cabinets</i>	98
MBS	<i>Current transformers</i>	102
ENSTO	<i>Shear head bolt connectors and lugs</i>	104



HRC fuses/ Striker fuses/aM fuses/Semiconductor

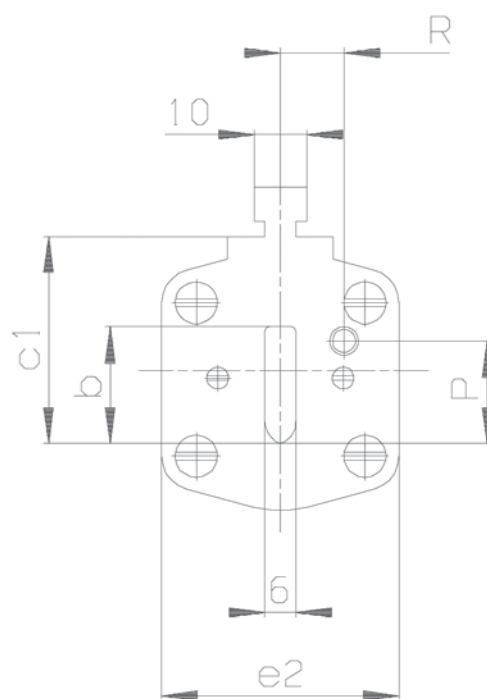
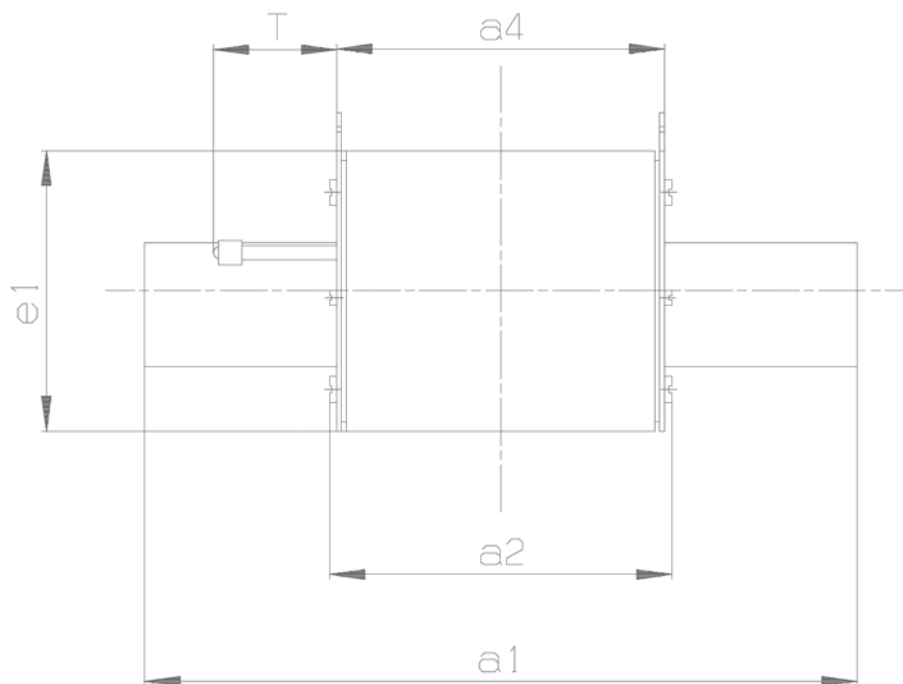

### HRC fuses

Type		SM000	SM00	SM1	SM2		SM3			SM4a	
500V	A	4-100	125-160	6-250	50-250	315-400	50-400	425-500	630	50-1000	1250-1600
	a1	78,5	78,5	135	150	150	150	150	150	200	200
	a2	53	53	72	72	72	72	72	72	87	87
	a4	50	50	67	67	67	67	67	67	90	90
	b	15	15	20	20	26	26	32	37	50	50
	c1	35	35	40	48	48	60	60	60	85	85
	e1	40	47	50	50	59	59	69	69	95	106
	e2	21	29	46	46	54	54	64	64	87	95
<b>Striker fuses only</b>											
	T	17	17	26	26	26	26	26	26	26	26
	R	0	0	13,7	16,2	16,2	17	17	17	24	24
	P	20,5	20,5	20,5	27,3	27,3	35,6	35,6	35,6	49	49

Dimensions in mm

### Semi conductor fuses

Type S		SM000	SM1	SM2	SM3
560/690V	A	10-160	6-250	50-400	50-630
	a1	78	135	150	150
	a2	55	72	72	72
	a4	48	65	65	65
	b	15	24	30	37
	c1	35	40	48	60
	e1	49	52	61	74
	e2	27	46	54	64

Dimensions in mm

### aM fuses

Type S		SM000	SM00	SM1	SM2	SM3
560V	A	16-63	80-160	125-250	200-400	500-630
	a1	78.5	78.5	135	150	150
	a2	53	53	72	72	72
	a4	50	50	67	67	67
	b	15	15	20	26	37
	c1	35	35	40	48	60
	e1	40	47	49	58	73
	e2	21	29	46	54	73

Dimensions in mm



## Solid link

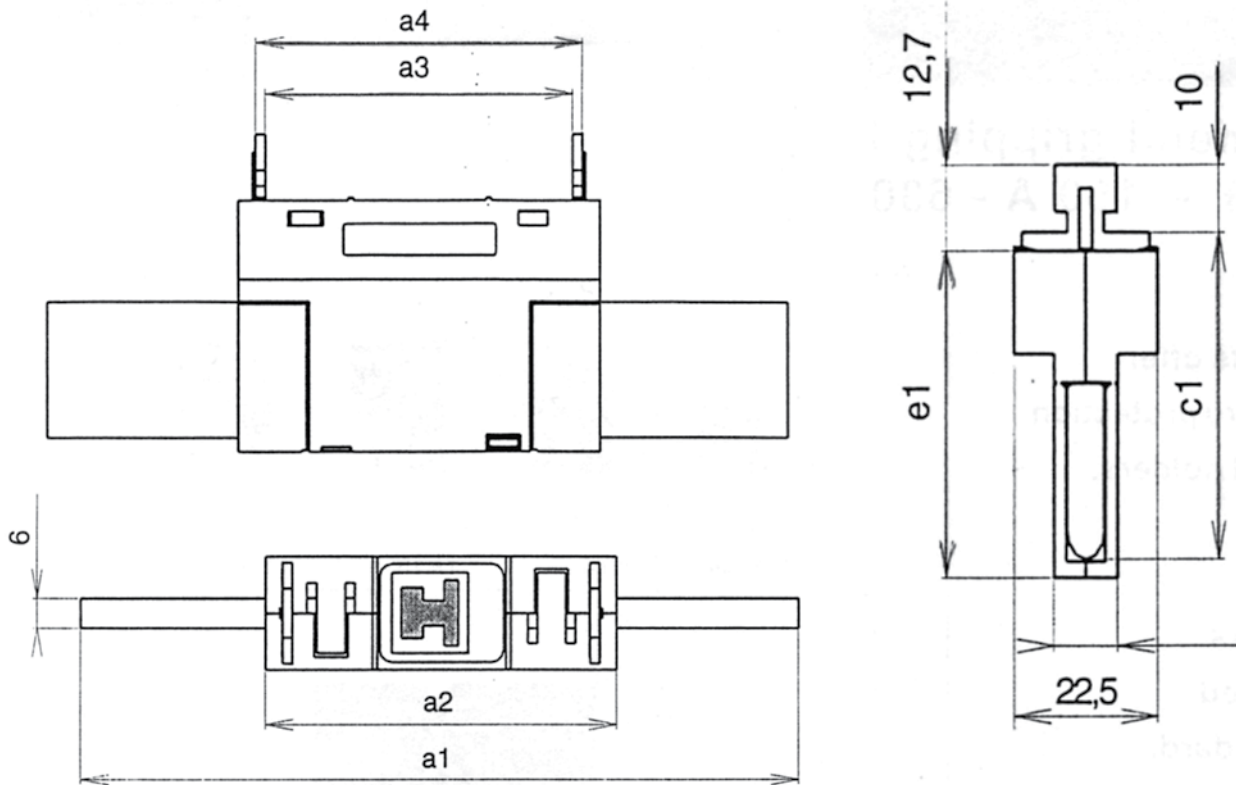

DIN size	a1	a2	a3	a4	c1	e1
TM00-ISM	80	54	44.4	48.4	35	35.1
TM1-ISM	135	73.5	62.4	66.4	40	40.1
TM2-ISM	150	73.5	62.4	66.4	48	48.1
TM3-ISM	150	73.5	62.4	66.4	60	60.1



## D-Type fuses & bases

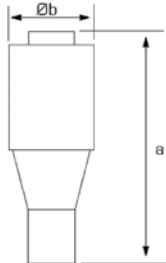

DIN size	Thread	Amps	a	Øb
D11	E27	10-25	50	21.8
D111	E33	35-63	50	28

### D-Type fuse bases

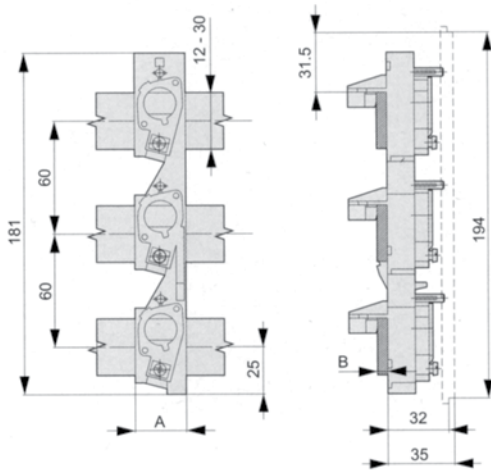

	A	A
RS60/273-5	45	45
RS60/333-5	54	5

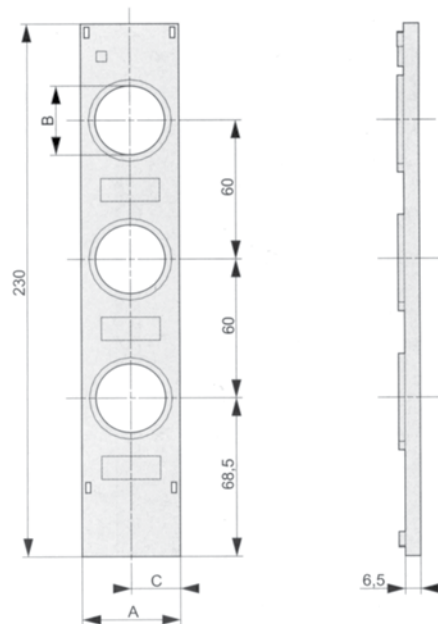

	A	B	C
ARS273/230	45	30	22.5
ARS333/230	54	36	27

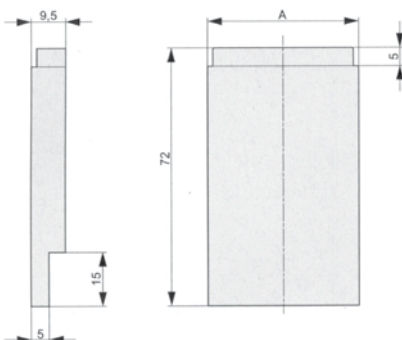

	A
GOURS273-60	42
GOURS333-60	57



ASRS-60



# Vertical disconnects

SL00-3X/185F

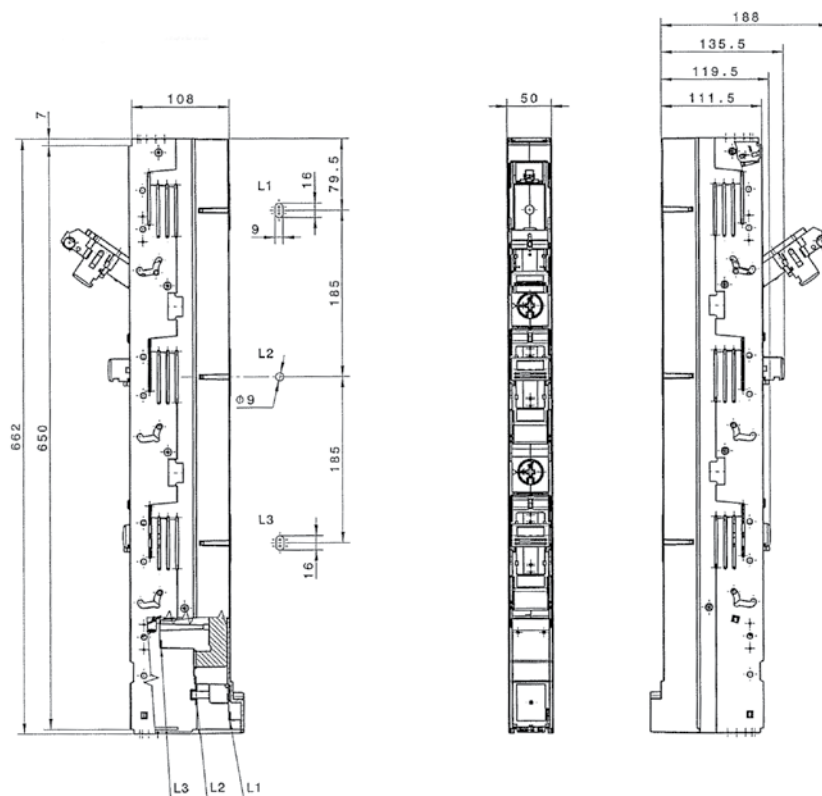

SL00-3X3/185F

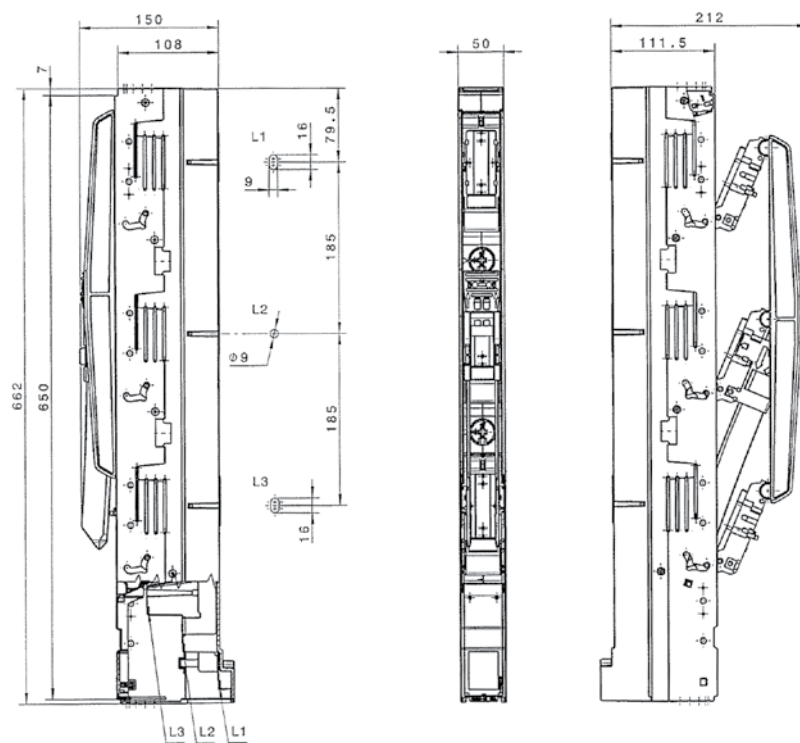





## Vertical disconnects

SL3-3X/1000/HA  
SL3-3X3/1000/HA

SL3-3X/1000 W/HA  
SL3-3X3/1000 W/HA

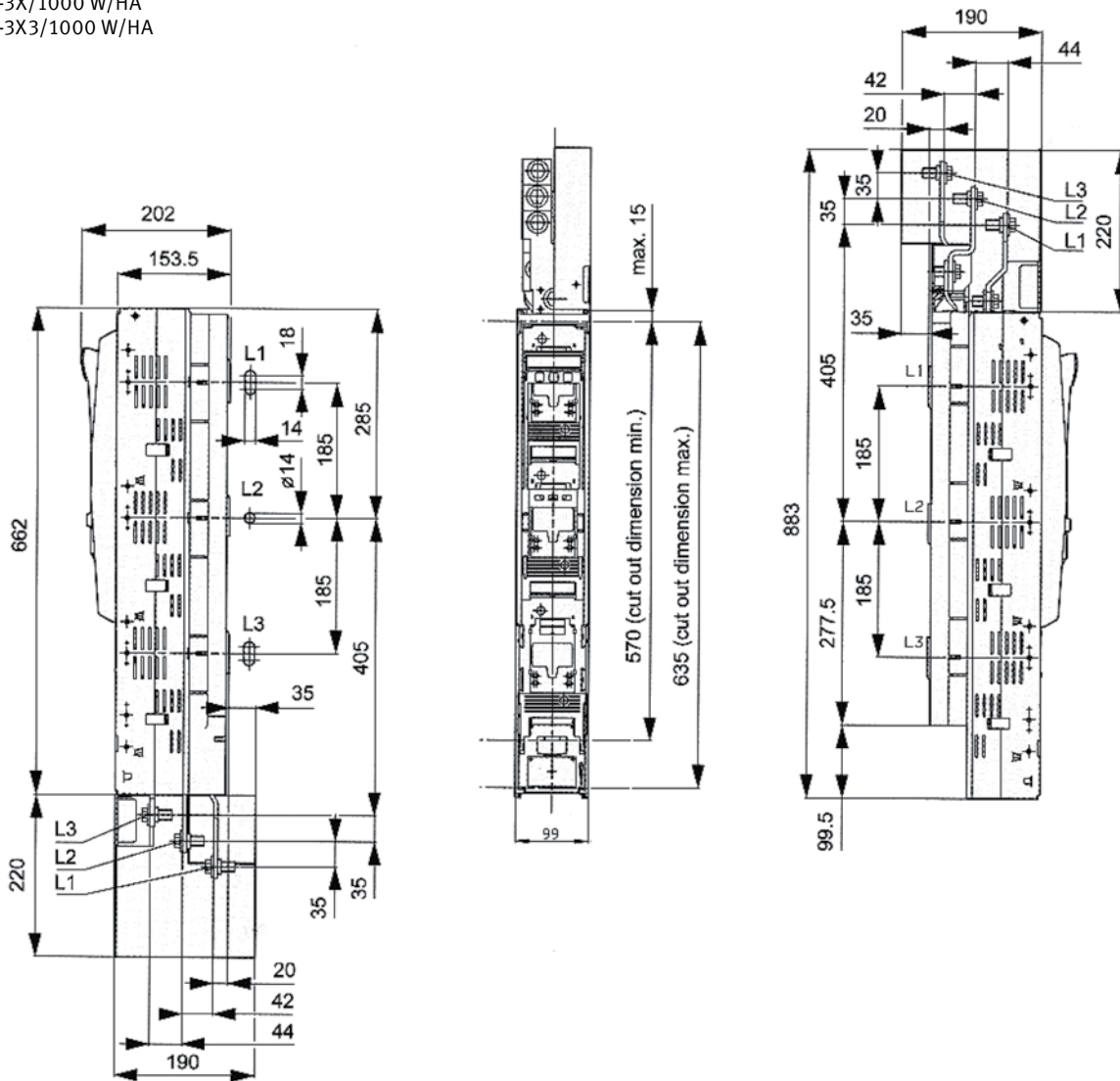

SL3-3X2/1250/HA  
SL3-3X6/1250/HA  
SL3-3X2/2000/HA

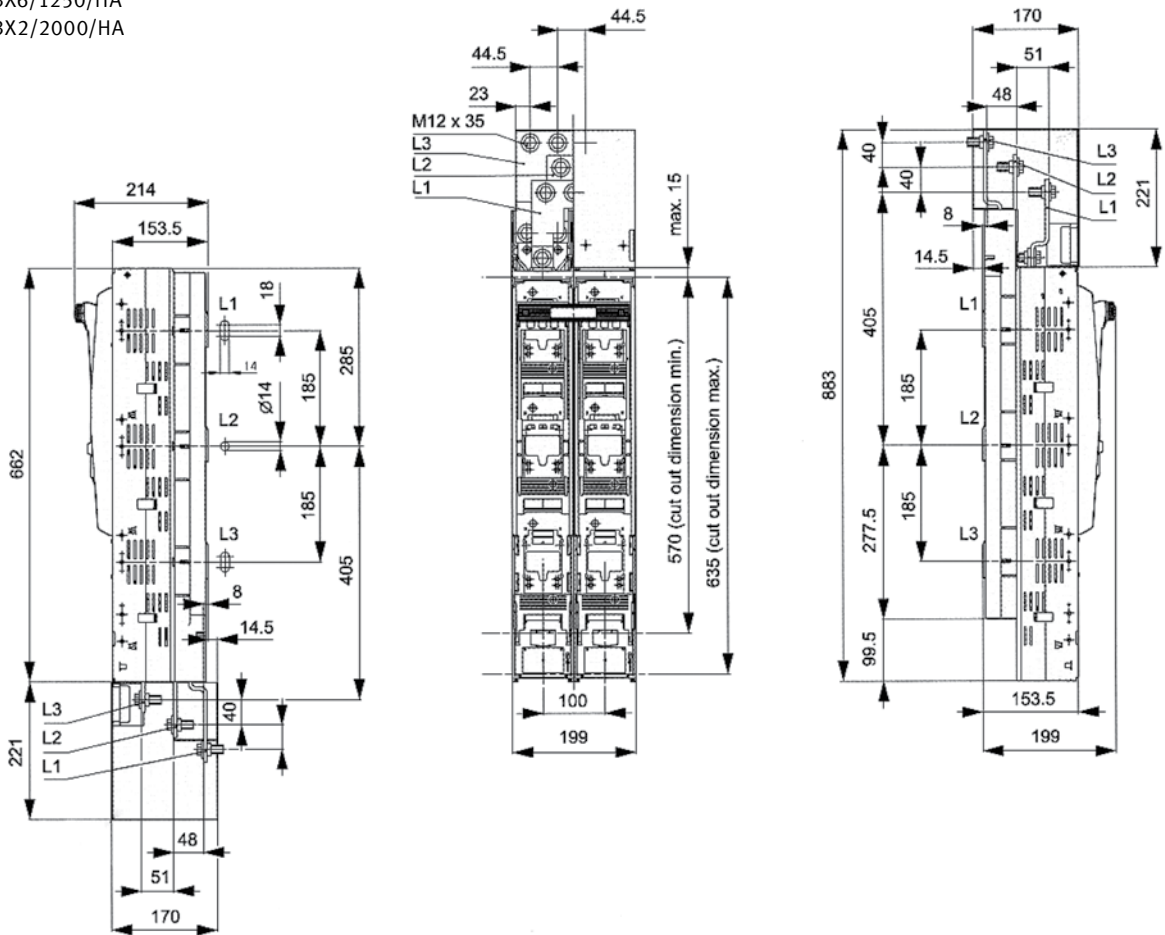



## Vertical disconnect accessories

### Terminals with connecting lugs K2G/A

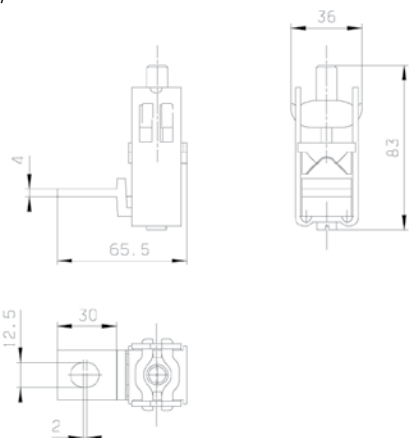

### K2HG/2/AF30

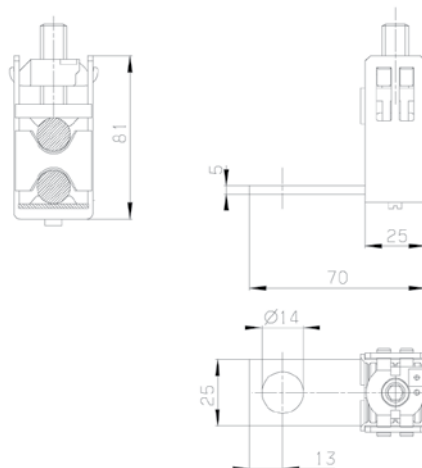

### KM2G/AF3040

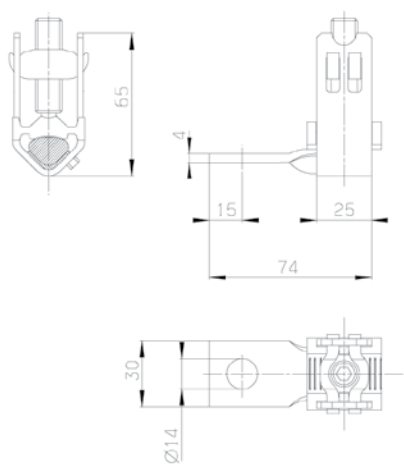

### KV2HG/2/AF30

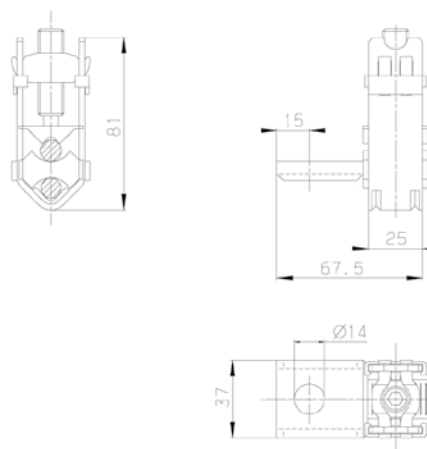

### Covers for terminals with connecting lugs HR

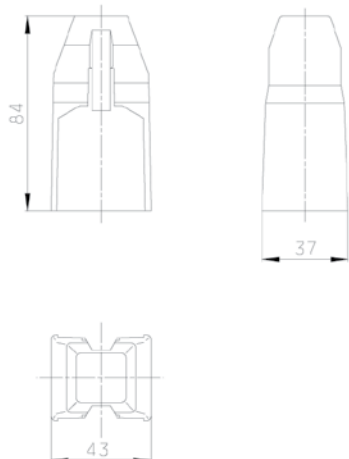

### HRV

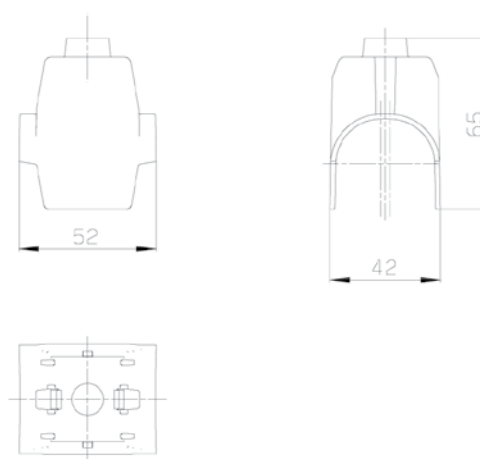

**Terminal covers**

HA/HA-SL00

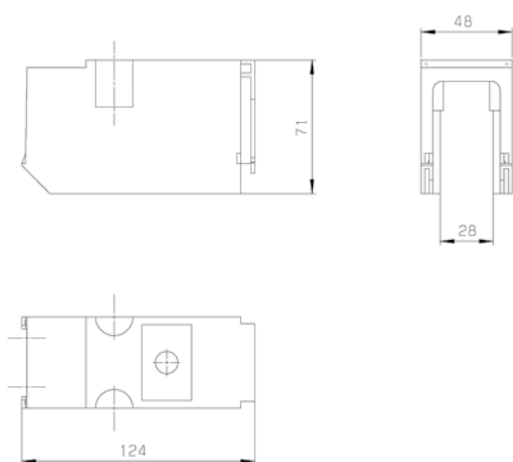

HA-SL123/10

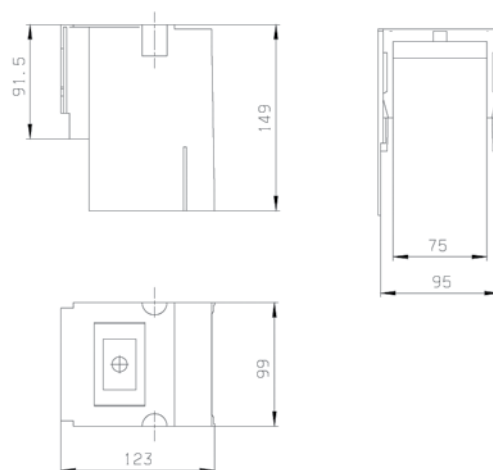



# Horizontal disconnects

LTL00-1/9

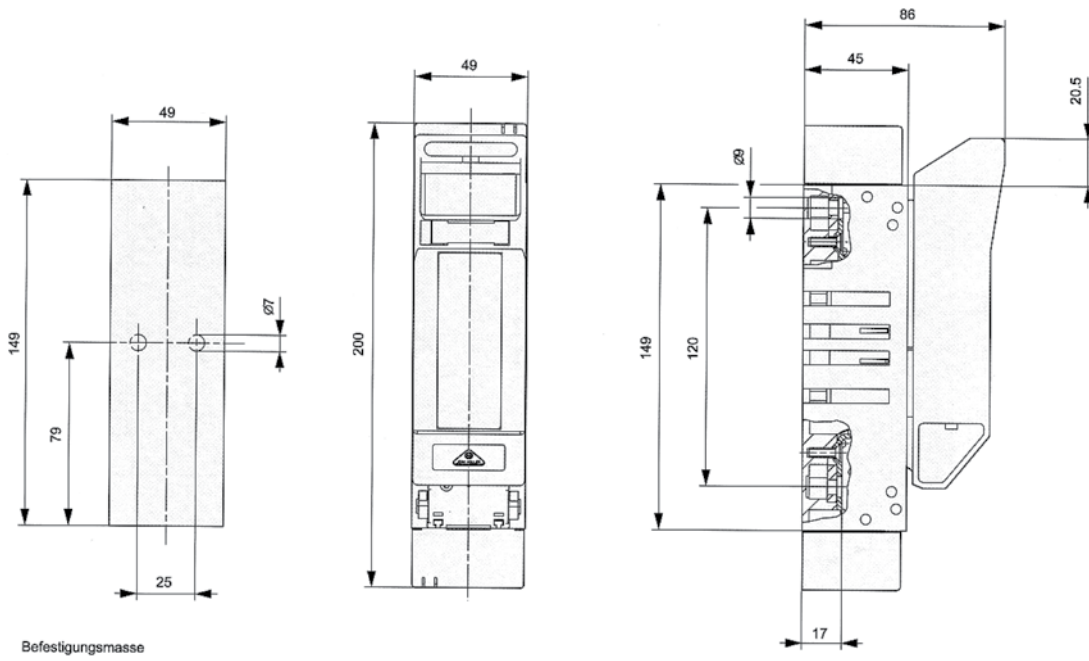

LTL1-1/9  
LTL3-1/9

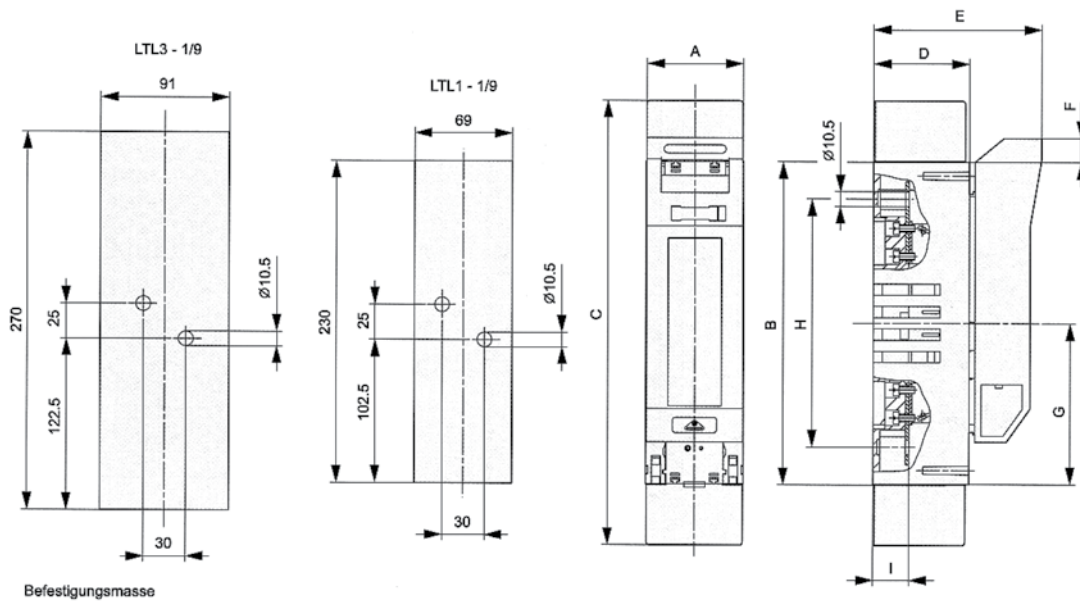

	A	B	C	D	E	F	G	H	I
LTL1-1/9	69	230	317	68	119	16.5	102.5	177	25
LTL3-1/9	91	270	431	96	147	9	122.5	220.5	30.5



LTL4a-1/1250/9  
 LTL4a-1/1600/9

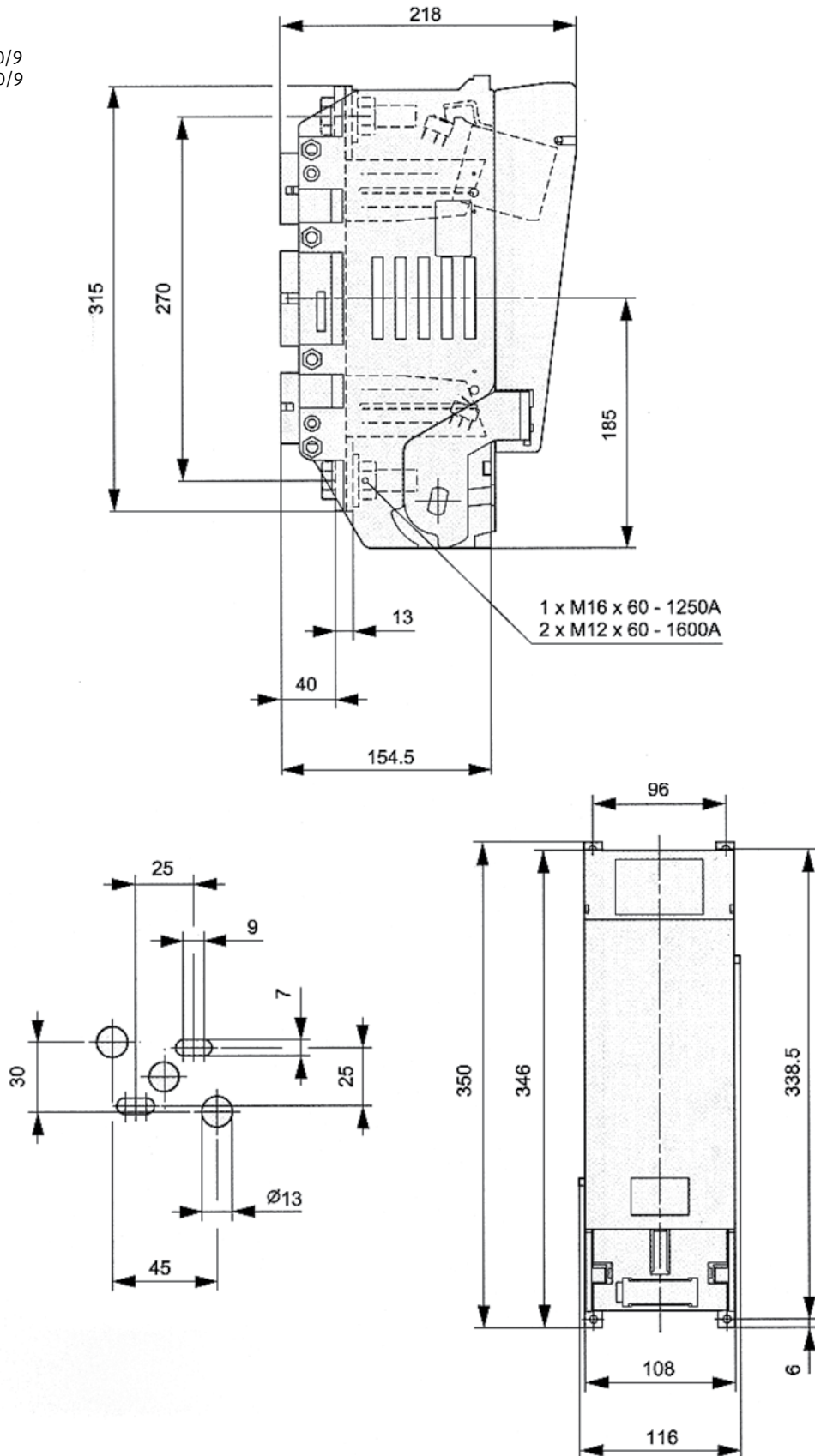



# Horizontal disconnects

LTL00-2/9

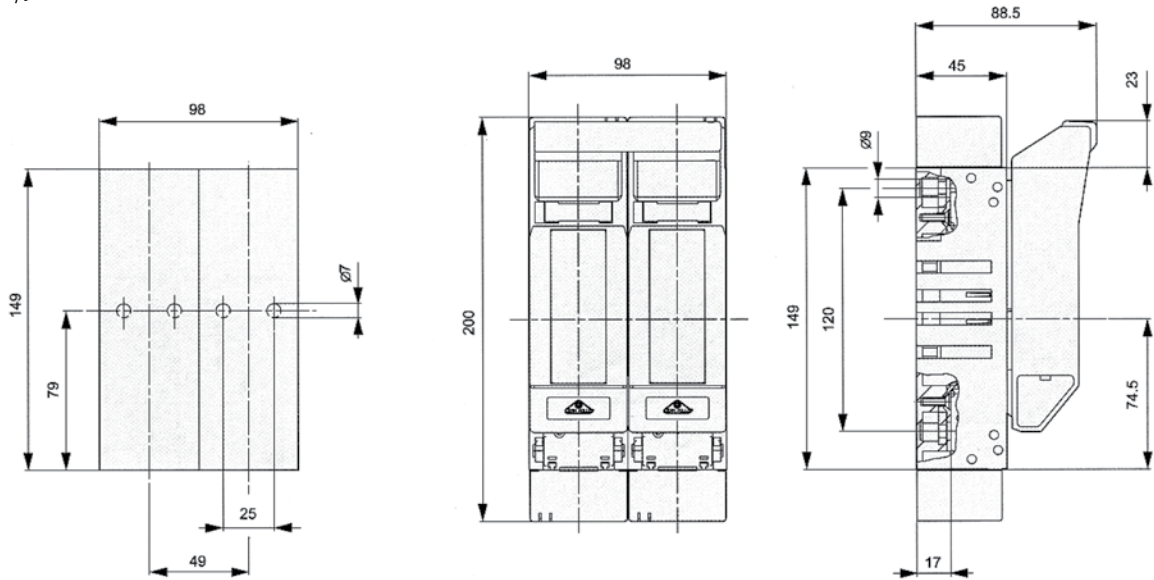

LTL1-2/9  
LTL3-2/9

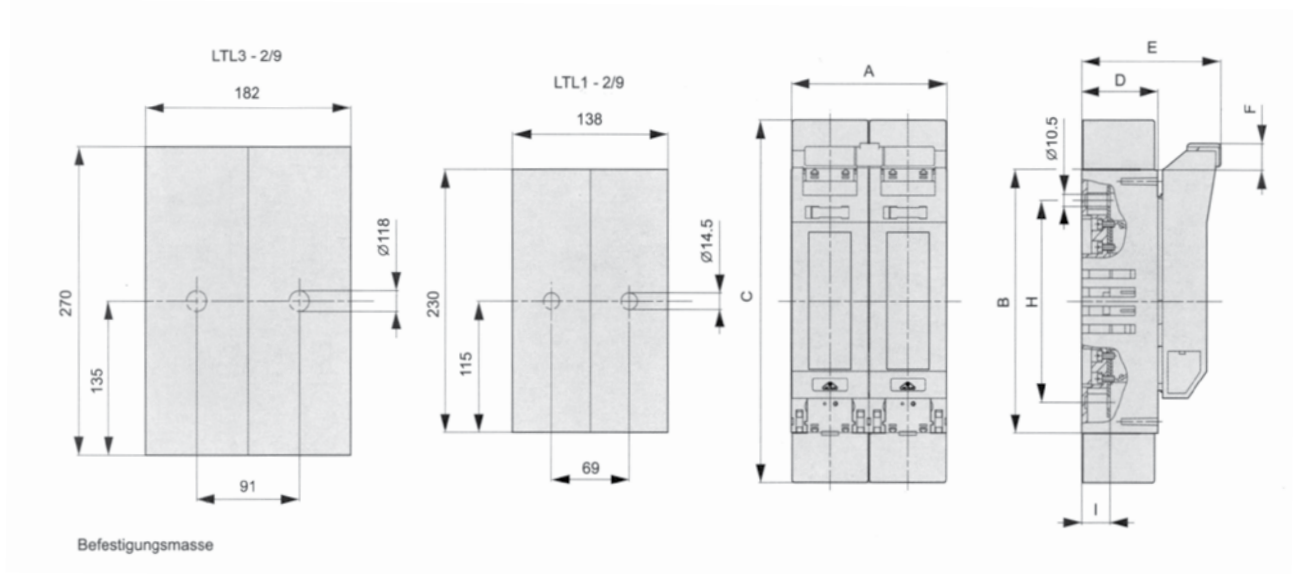

Befestigungsmasse

	A	B	C	D	E	F	G	H	I
LTL1-2/9	138	230	317	68	123.5	23	115	177	25
LTL3-2/9	182	270	430	96	151.5	15.5	135	220.5	30.5

LTL00-3/9  
LTL1-3/9  
LTL2-3/9  
LTL3-3/9

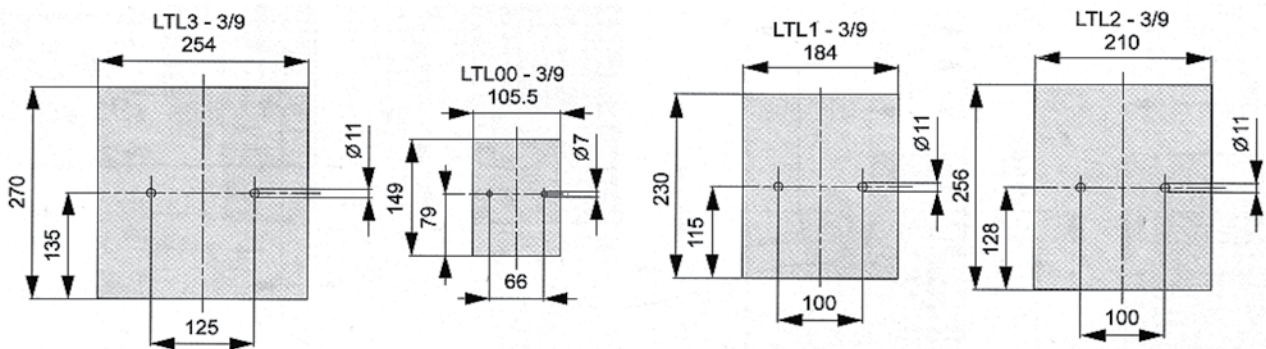
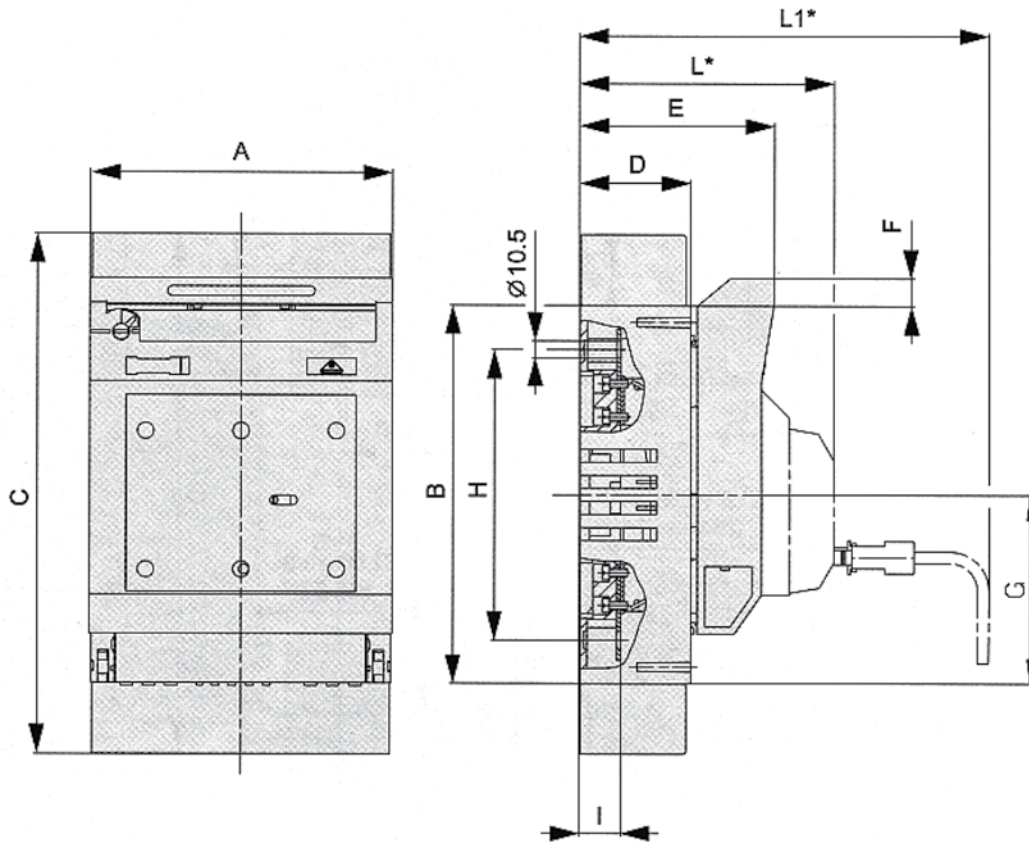

	A	B	C	D	E	F	G	H	I
LTL00-3/9	89	139	-	48	78.5	0	70	112	15
LTL00-3/9	105.5	149	200	45	86	20.5	74.5	120	17
LTL1-3/9	184	230	317	68	119	16.5	115	177	25
LTL2-3/9	210	256	397	81	133	16.5	128	205	25
LTL3-3/9	254	270	430	96	147	9	135	220.5	30.5



## Horizontal disconnects

LTL4A-3X3/1250/9  
LTL4A-3X3/1600/9

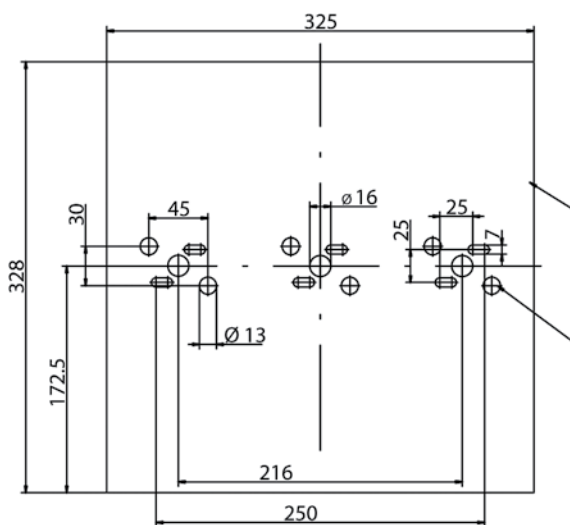
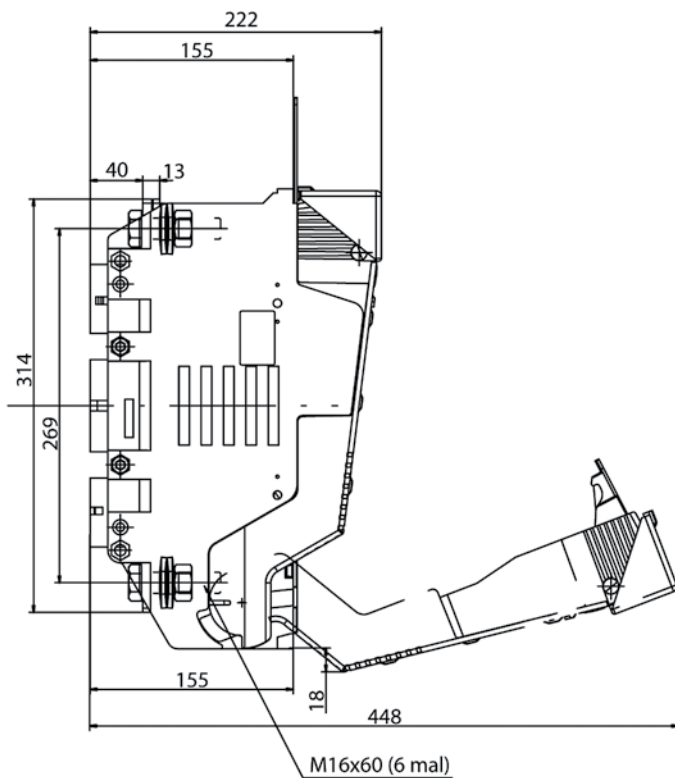
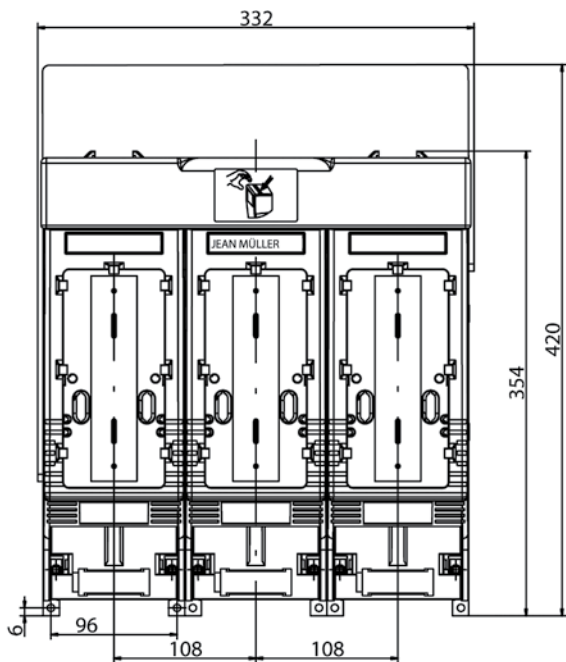

LTL00-1/SK

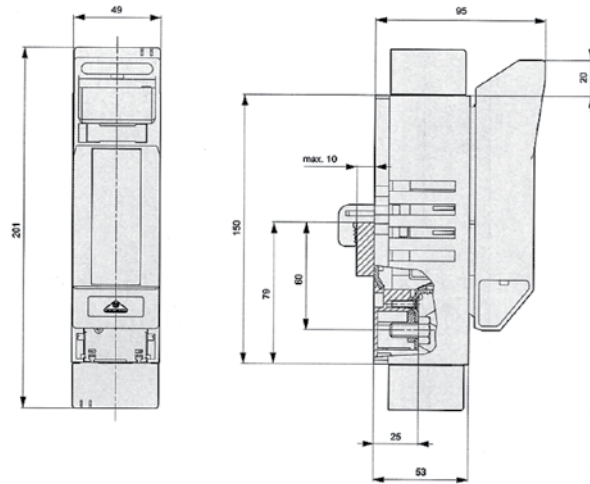

LTL1-1/SK

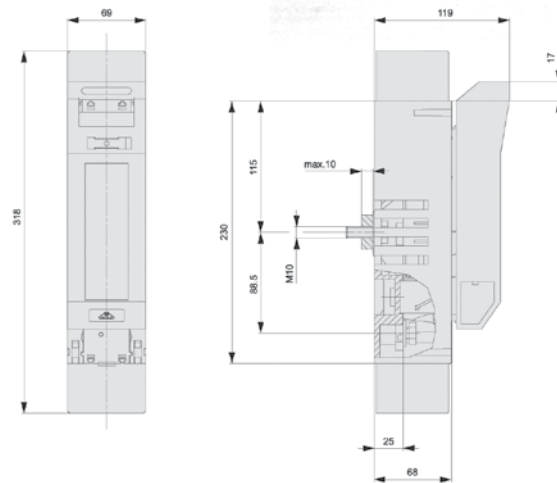

LTL3-1/SK

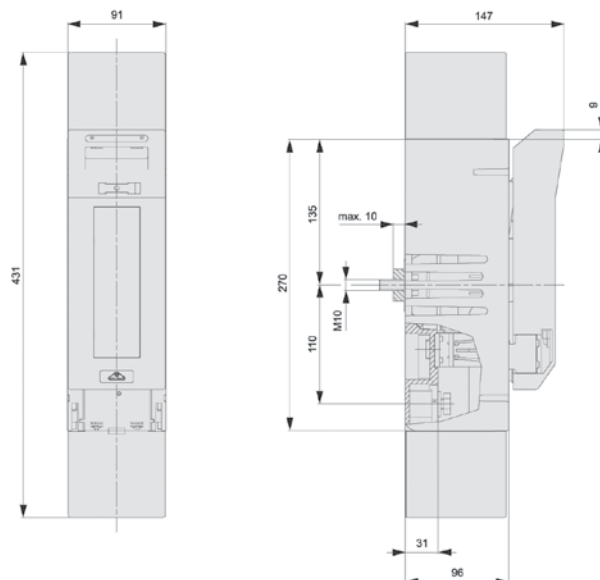



## Horizontal disconnects

LTL000-3/9/60/F57/F5

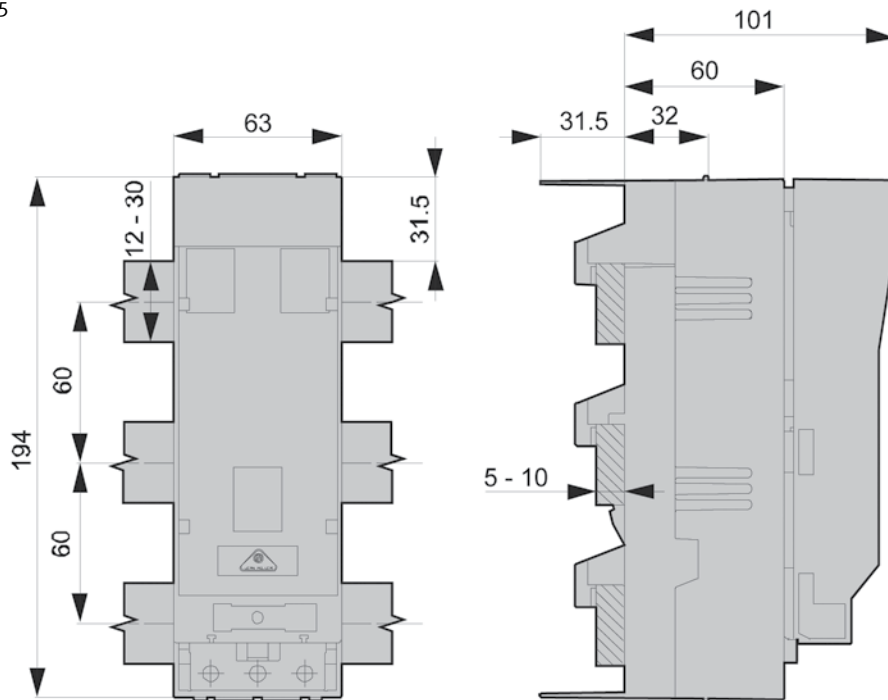

DSL-60/183-5

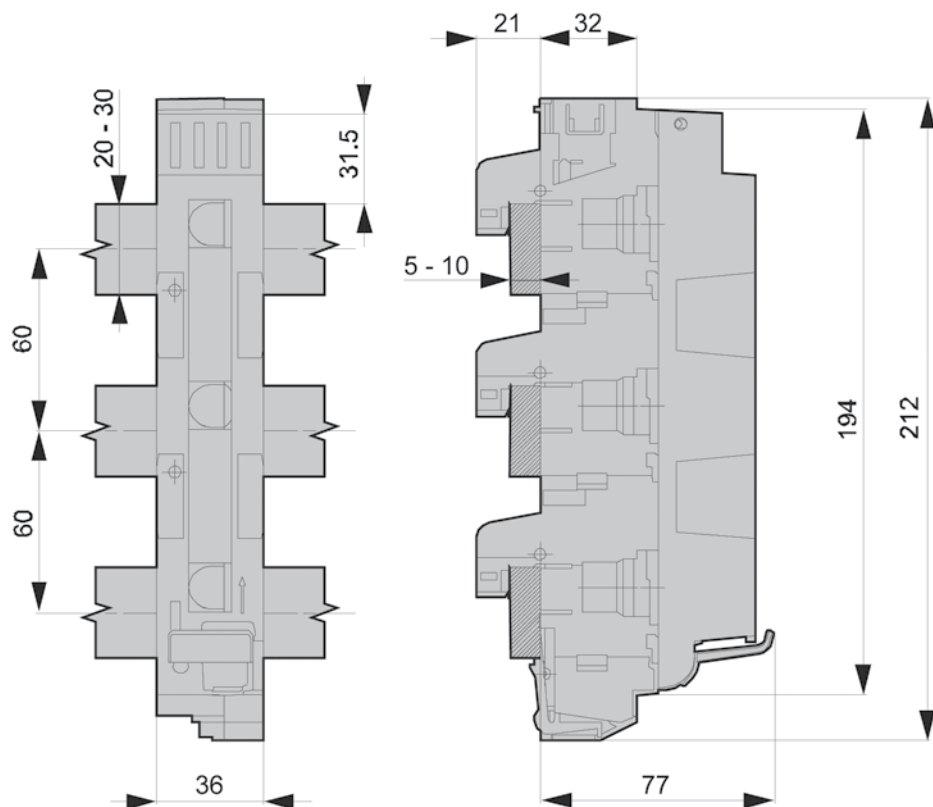

LTL00-3/9/4060/S

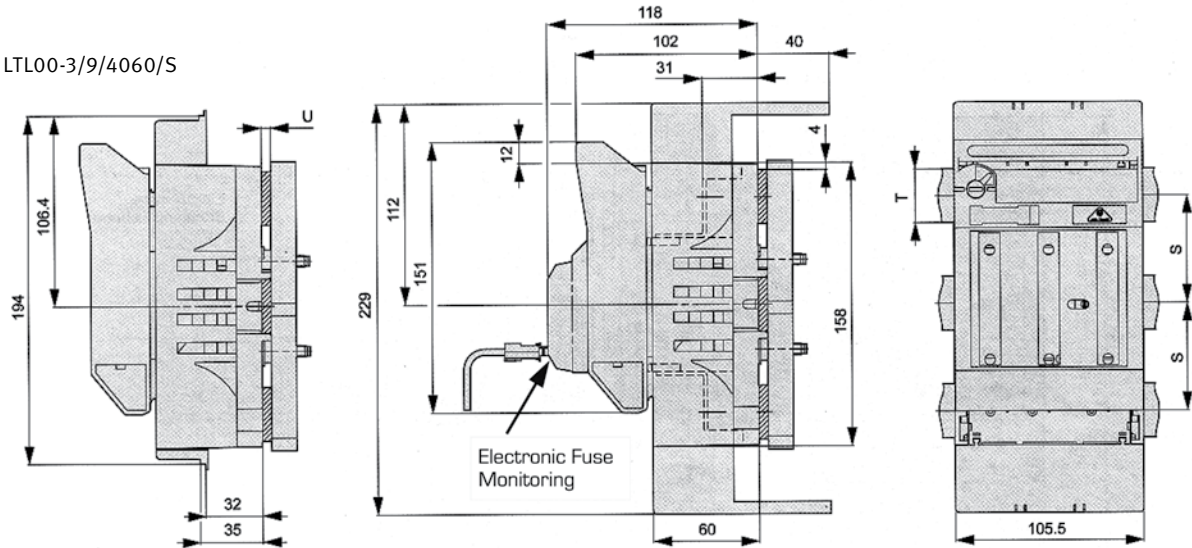

	S	T	U
LTL00-3/9/4060/S	40	20-30	5 or 10
	60	20-30	5 or 10

LTL1-3/9/60/AU  
LTL2-3/9/60/AU  
LTL3-3/9/60/AU  
LTL1-3/9/100/AU  
LTL2-3/9/100/AU  
LTL3-3/9/100/AU

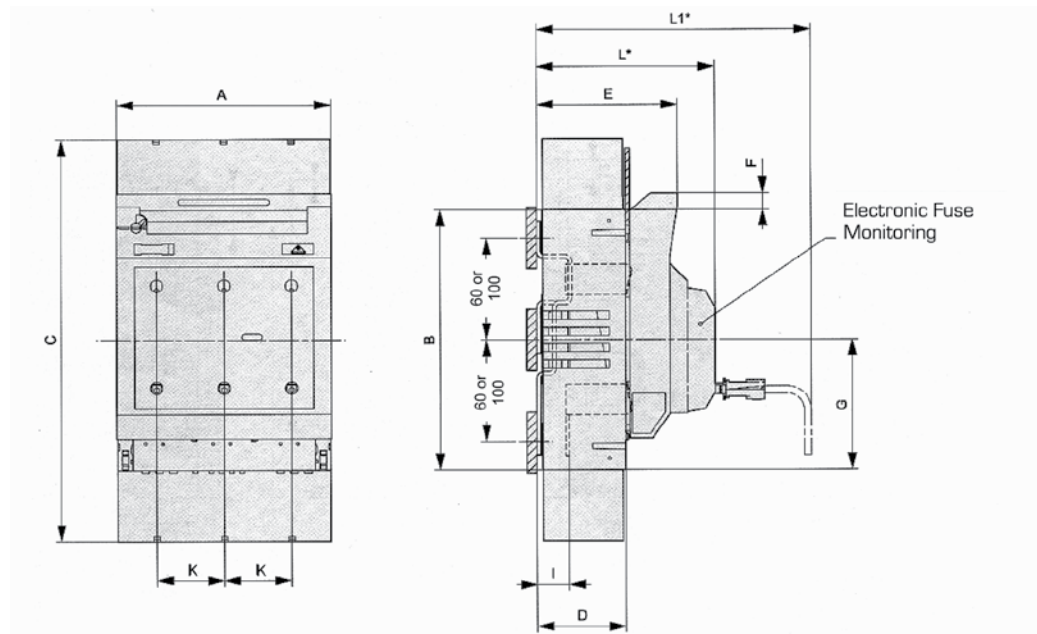

	A	B	C	D	E	F	G	I	K
<b>60mm Spacing</b>									
LTL1-3/9/60/AU	184	230	320	70	121	16.5	115	27	58
LTL2-3/9/60/AU	210	256	400	83	135	16.5	128	27	66
LTL3-3/9/60/AU	254	270	430	120	170	9	135	54	82
<b>100mm Spacing</b>									
LTL1-3/9/100/AU	184	230	320	74	126	16.5	115	30.5	58
LTL2-3/9/100/AU	210	256	400	87	142	16.5	128	30.5	66
LTL3-3/9/100/AU	254	270	430	104	150	9	135	37	82



# Busbar system components

SST-60/49-3

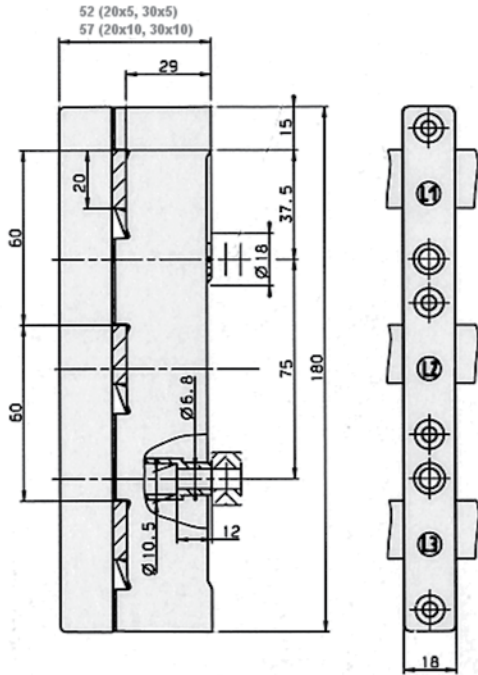

AM-60/250/3

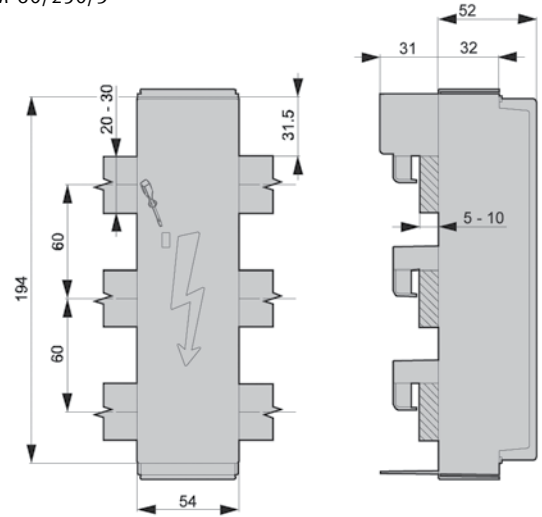

AM-60/630/3

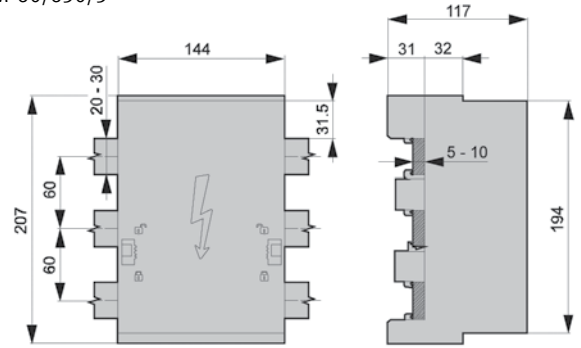

H-RF

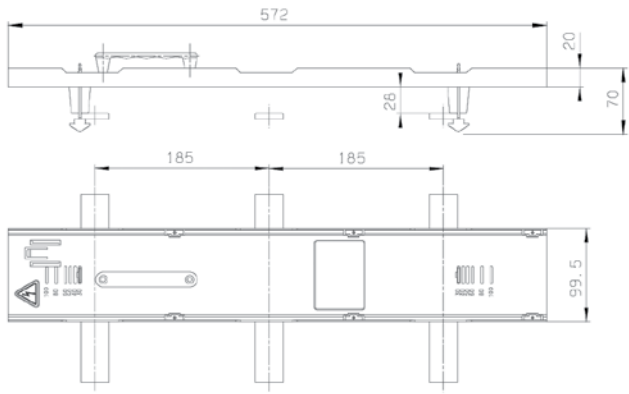

H-SL00

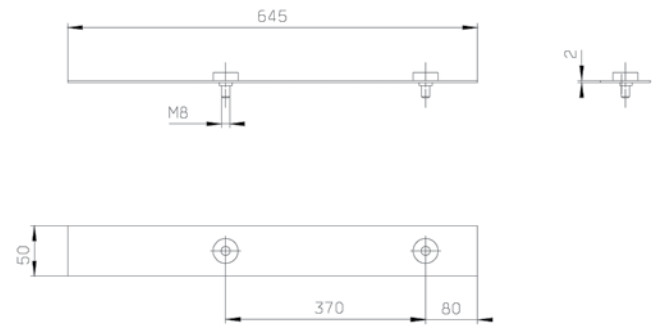

ASST-60/3

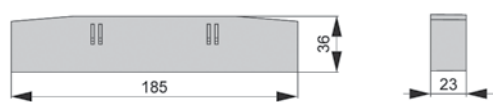



WH-BSC/3P

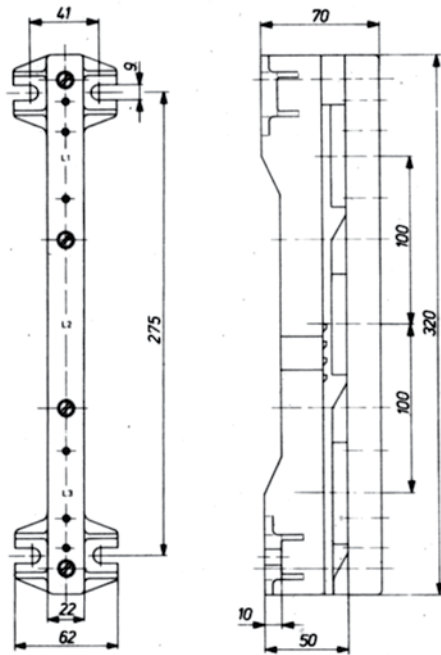

AH-SL

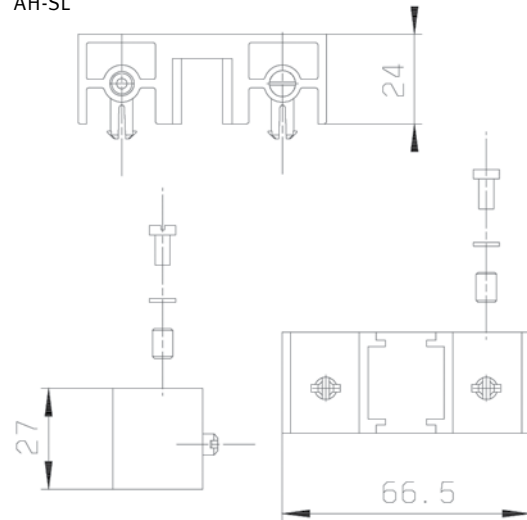

AL-SL00/42

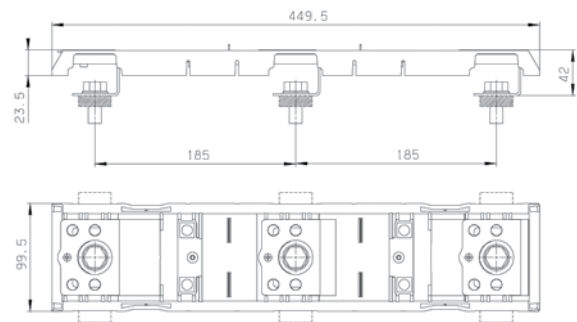

AB-SL00/1

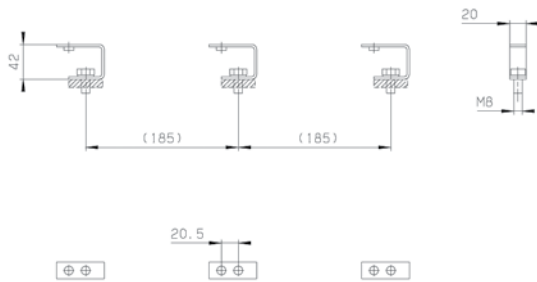

SH-100/185

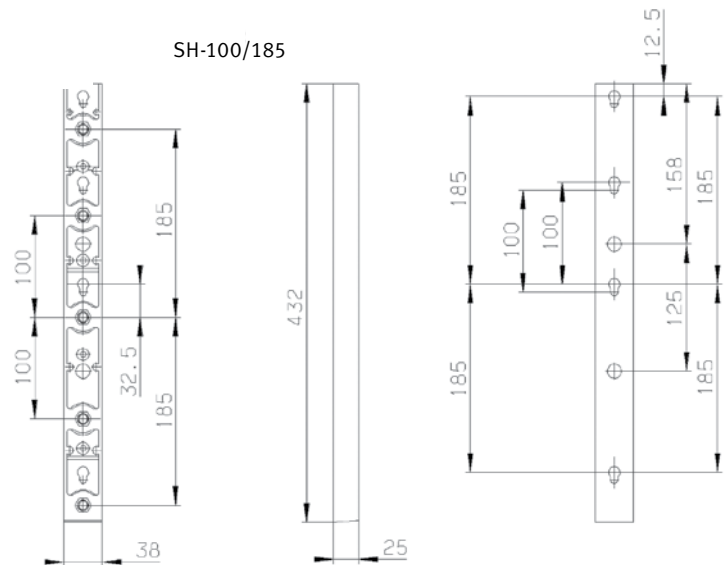



# Rack system

JMTE-BBS3

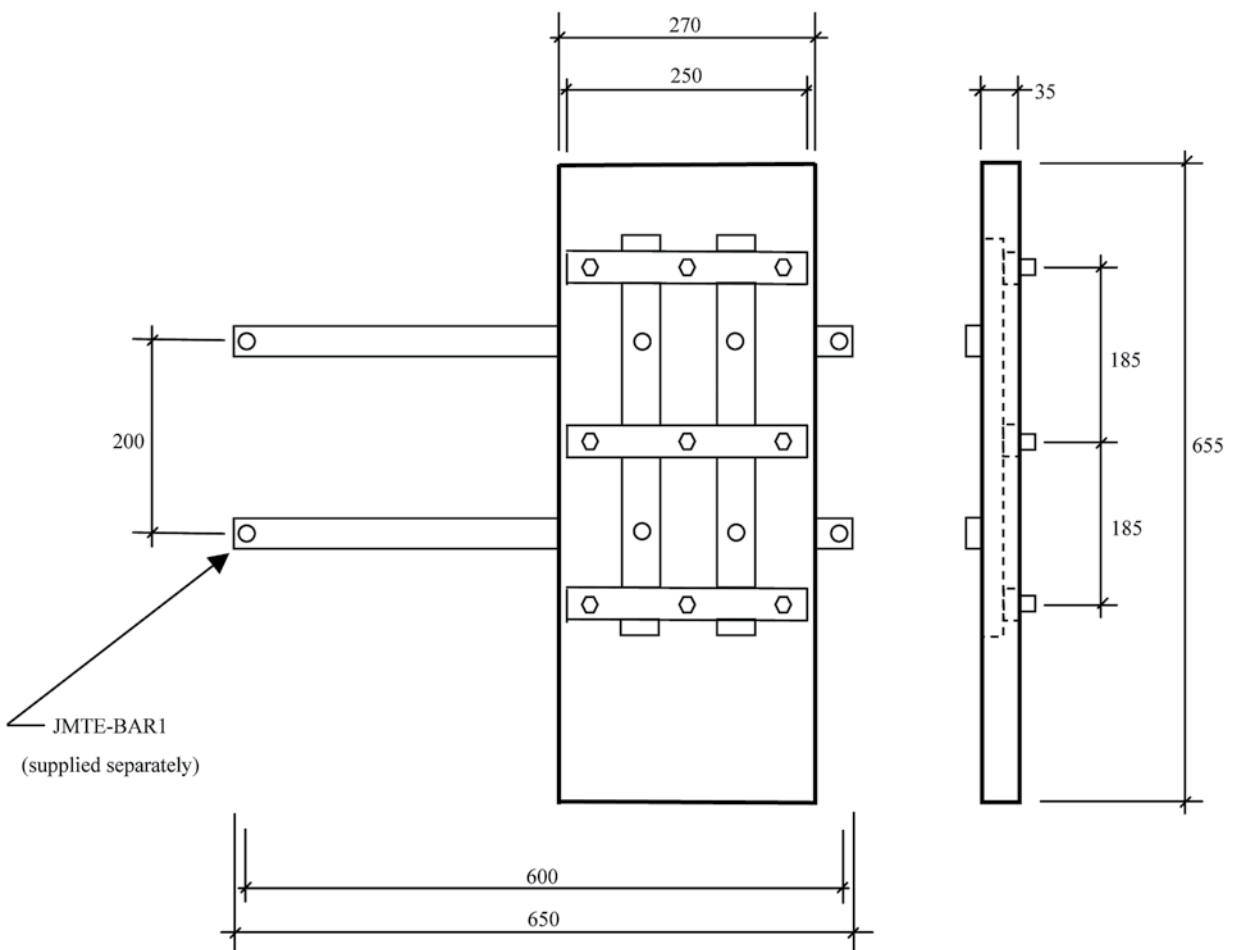

JMTE-BBS6

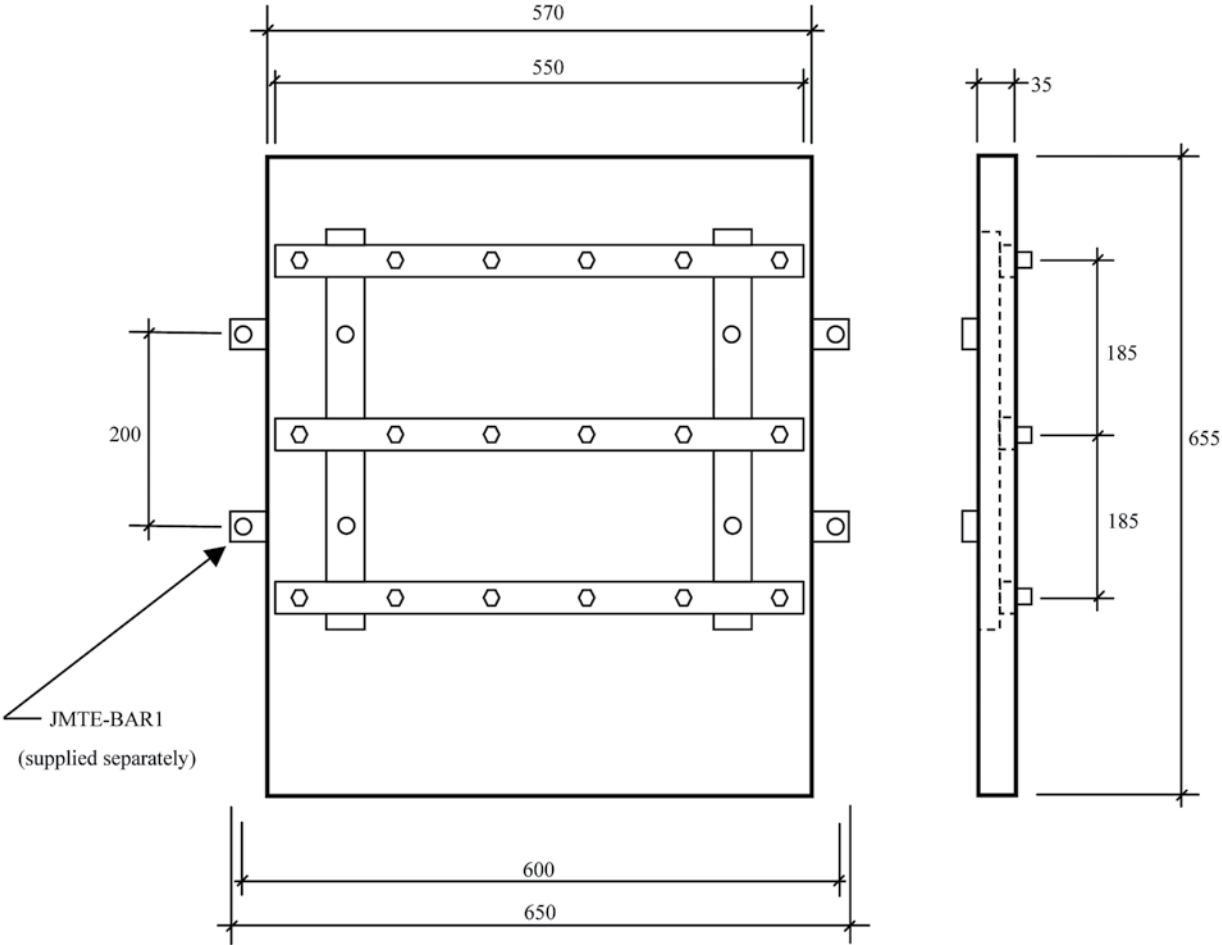



# Cabinets

EHFB

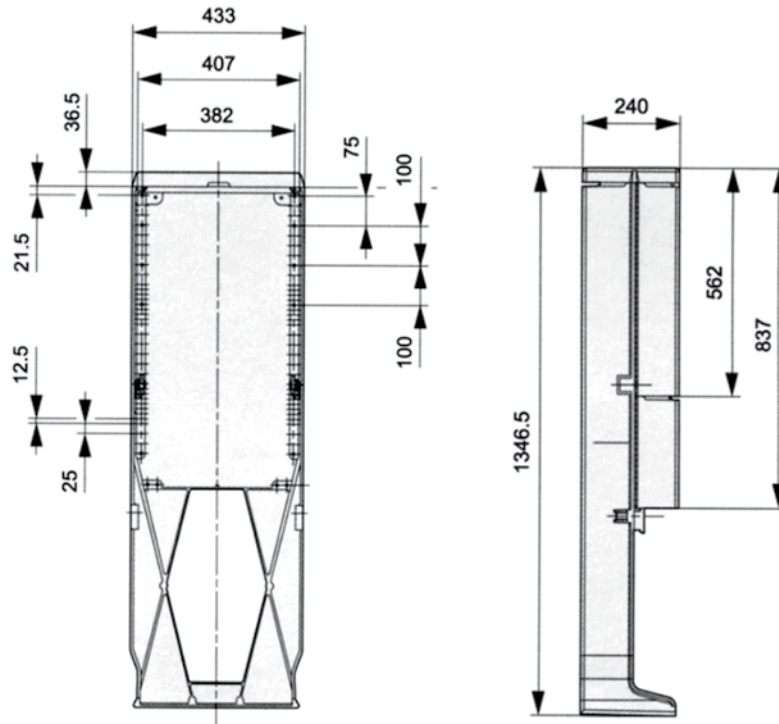

EHFERB

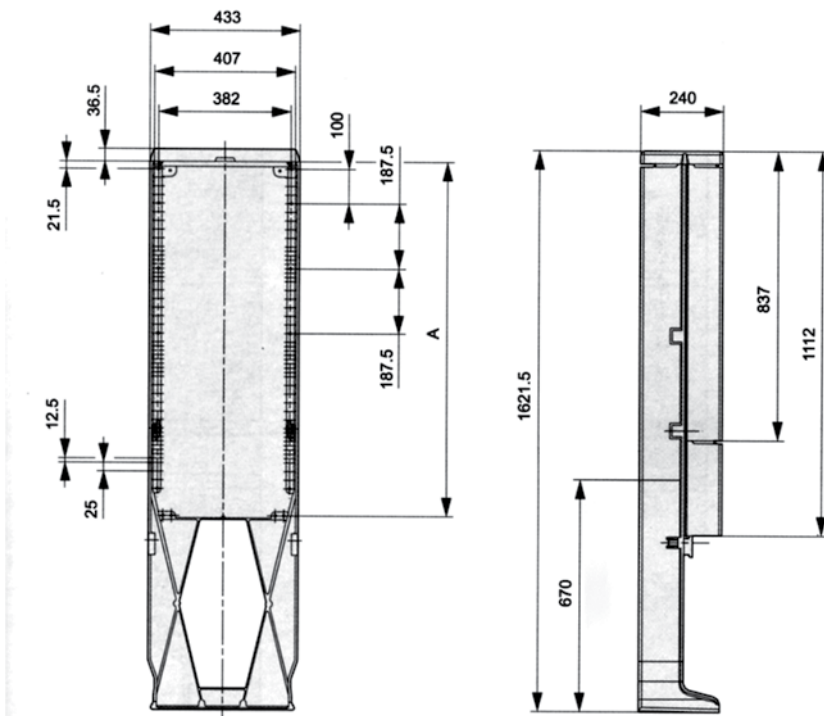

EHFERB

KVS00/10

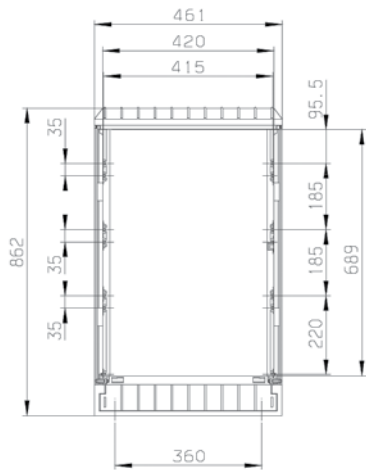

KVS1/10

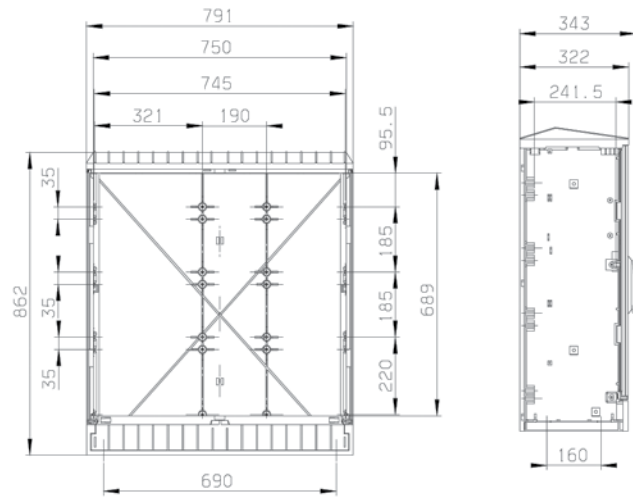

KVS0/10

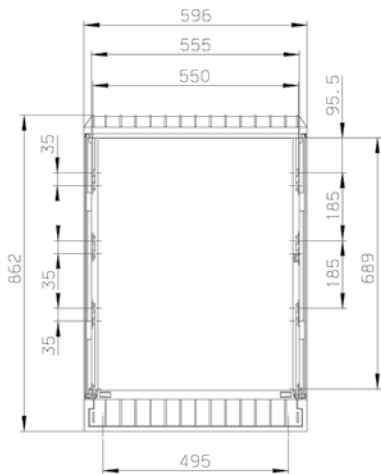

KVS2/10

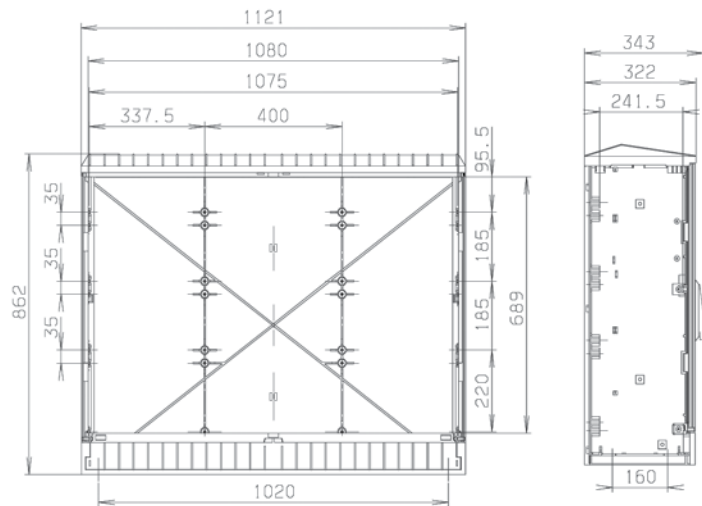



# Cabinets

NKVS0

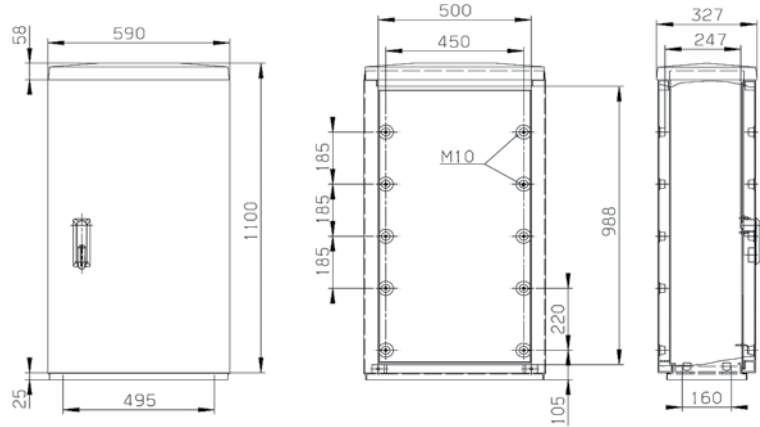

NKVS1

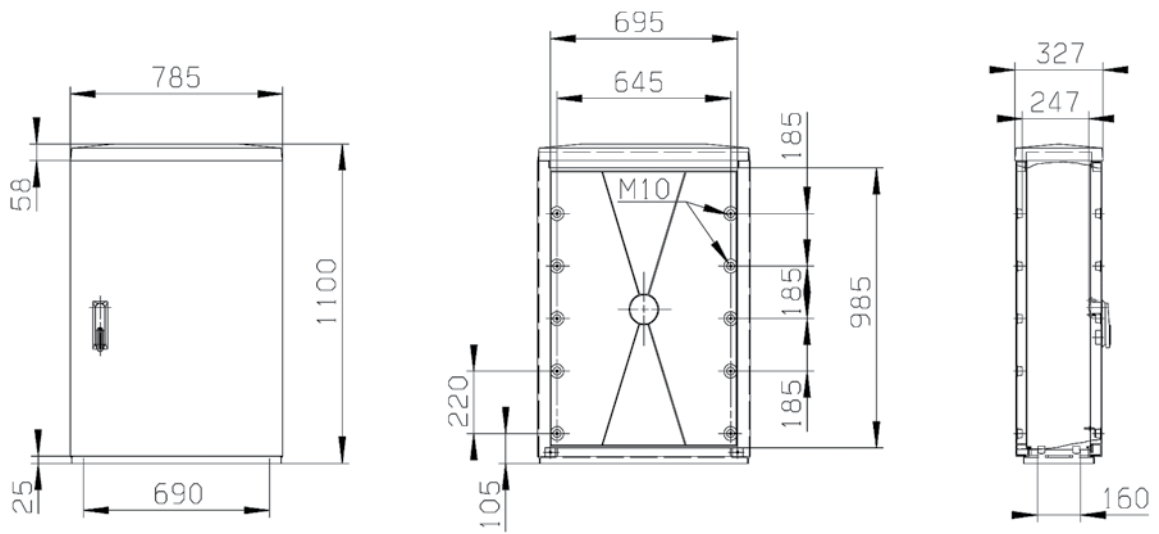

NKVS2

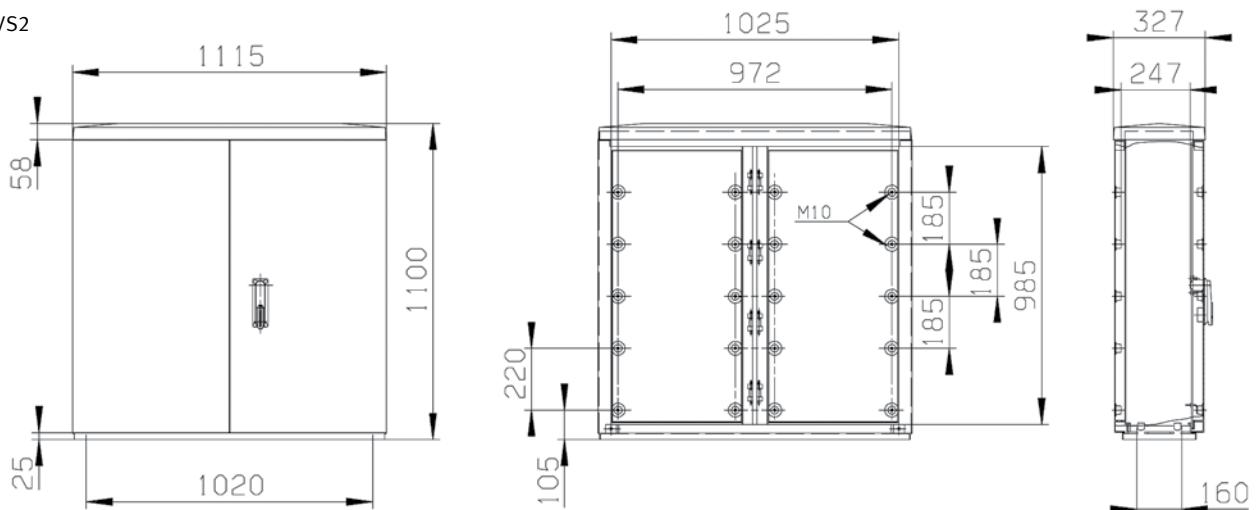

FP00  
FP0  
FP1  
FP2

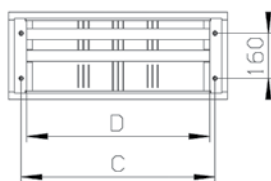
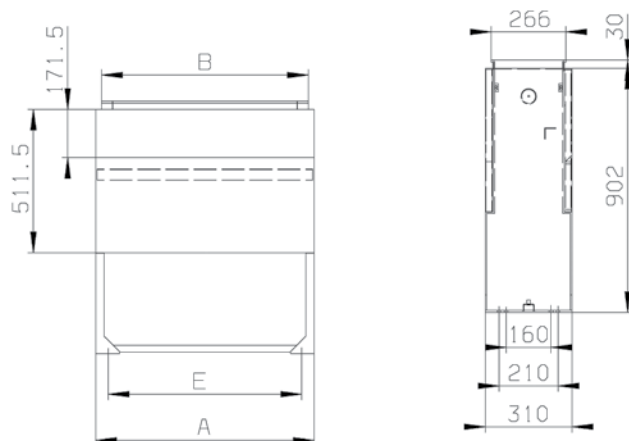

	A	B	C	D	E
FP00	450	408	360	322	360
FP0	585	543	495	457	495
FP1	780	738	690	652	690
FP2	1110	1068	1020	982	1020



Current transformers

ASK31-3

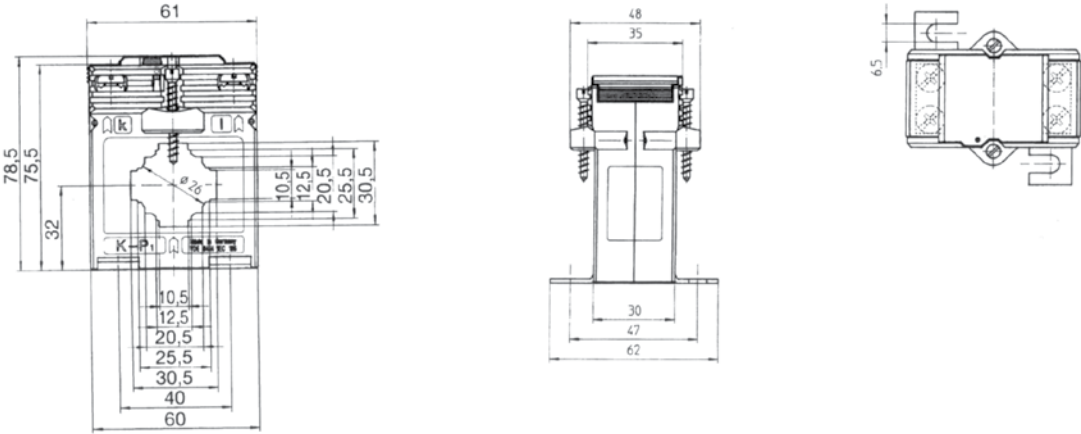

ASK101-4

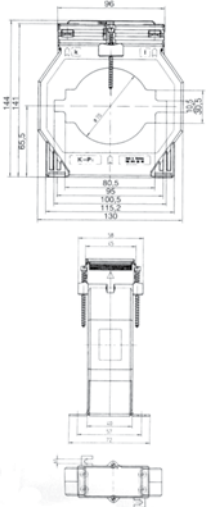

ASK51-4

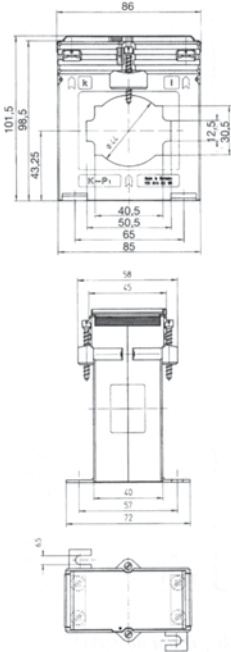

ASK128.4

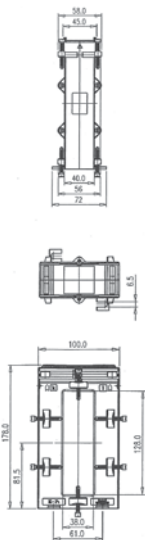



## DB Standoff Insulators

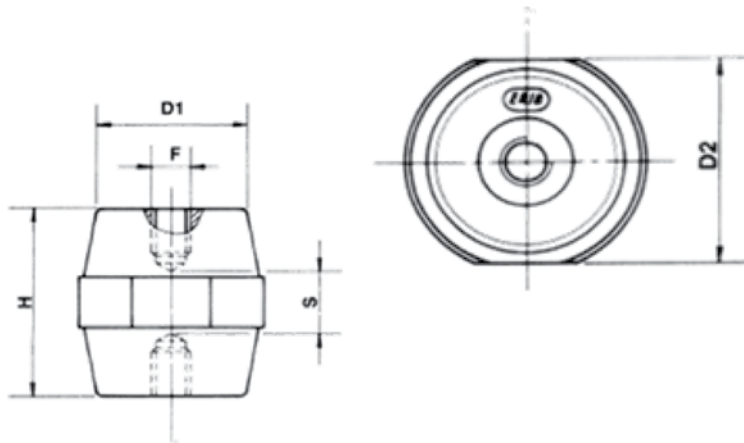

	F	H	D1	D2	S
DB25	M6	25.2	15	19	9
DB34	M8	35	28	32	10
DB34	M10	35	28	50	10
DB50	M10	51	29	36	20
DB65	M10	63.5	35	41	30

## Shear head bolt connectors & lugs

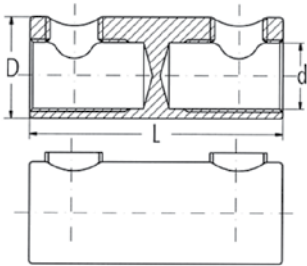

	L	D	d
ESLJ6-50	54	20	11
ESLJ35-95	58	31	20
ESLJ95-240	119	38	26
ESLJ150-300	130	43	29

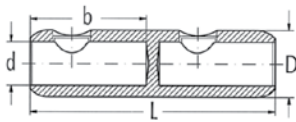

	L	D	d
ESMJ10-95	70	25	14
ESMJ95-240	120	34	20.5

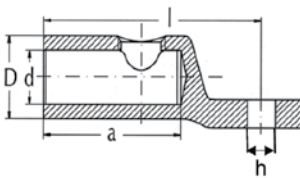

	L	D	d	h	Palm Width
ESAL6-50	50	20	10	10.3	20
ESAL50-95	74	25	15	10.5	25
ESAL95-185	85	30	19	12.5	30
ESAL150-300	114	42	29	12.5	42
ESML10-95	60	26	14	13	26
ESML95-240	103	34	20	17	34

## *Terms and Conditions of Trade*

These terms of trade are incorporated into any contract of sale of goods and services (“Goods”) between Jean Müller (New Zealand) Limited (the “Supplier”) and its customers (each a “Customer”).

These terms of trade prevail over any other terms and conditions, or other form of contract despite any indication to the contrary by any person acting or apparently acting on behalf of the Supplier, unless agreed in writing by a duly authorised officer of the Supplier.

### **Orders**

Orders for Goods must be placed in accordance with the Supplier’s procedures as promulgated from time to time. Receipt by the Supplier of any Customer order will be deemed to be acceptance by the Customer of these terms of trade, despite anything to the contrary in the Customer’s order.

### **Price**

The prices for Goods are those contained in the Supplier’s price list current at the time of the order. The Customer must also pay any taxes and duties which may be applicable, including GST payable in respect of Goods in accordance with the Goods and Services Tax Act 1985.

The Supplier will give as much notice as it reasonably can of any price changes.

### **Payment**

Unless otherwise agreed in writing payment is due on the 20th of the month following the date of the Supplier’s invoice.

The Customer may not withhold payment or make any deductions from any amount owing in respect of the supply of Goods without the Supplier’s prior written consent.

There is no prompt payment discount unless specifically agreed in writing by the Supplier and the Customer.

All payments received will be credited chronologically against invoices which are issued earlier in time regardless of whether the payment is stated to be for a later invoice.

### **Delivery**

The Supplier will deliver, or arrange delivery of the Goods to the place specified in the Customer’s order.

The Supplier reserves the right to charge freight for despatches under the value of \$50 or for bulky deliveries such as cabinets and distribution racks. Otherwise, unless specifically agreed to the contrary in writing, the Supplier will absorb the costs of, and incidental to, transportation of Goods having a value above \$50.

The freight cost for deliveries outside New Zealand is to be negotiated between the Supplier and the Customer.

If the Customer refuses to accept delivery of Goods the Supplier may charge the Customer for any additional costs incurred as a result, including storage and transportation costs.

The Supplier will use its best endeavours to fulfil orders which have been confirmed by the Supplier, but will not be liable for any failure to deliver or delay in delivery.

### **Retention of title**

The title to Goods delivered remains with the Supplier until payment has been received in full by the Supplier.



### **Risk and ownership**

Risk of any loss, damage or deterioration of or to the Goods passes to the Customer on delivery. The Customer is responsible for insuring Goods from the time of delivery.

Despite any period of credit, Ownership of the Goods remains with the Supplier and does not pass to the Customer until the Customer:

- pays the price of the Goods (and other related sums including any transportation costs and any applicable duties or taxes) to the Supplier (“Customer Debt”); or
- resells the Goods in accordance with these terms provided that the proceeds from any such resale are held in trust in accordance with the provisions set out in this “Risk and Ownership” section;

While Ownership of the Goods remains with the Supplier:

- the Customer must store them separately in a saleable condition as fiduciary, bailee and agent of the Supplier and clearly identify them as belonging to the Supplier;
- the Customer may (until advised to the contrary in writing by the Supplier), in the ordinary course of its business, use the Goods or sell them for full value, provided that the proceeds from any such resale are held in trust in accordance with the provisions set out in this “Risk and Ownership” section; and
- as the Customer’s irrevocably appointed agent for the purposes of this clause, the Supplier may, if the Supplier has reasonable grounds to believe that the Customer has not complied with these terms or an Event of Default has occurred or is likely to occur, enter the premises where the goods are stored and remove them. The Supplier will not be responsible for any damage reasonably caused in entering and removing the Goods. The Customer will indemnify the Supplier for any costs or liability incurred by the Supplier as a result of any such damage. The Customer is liable for all costs of the Supplier (including transportation and storage charges) of and incidental to entering and removing the Goods. The Supplier may resell any of the Goods and apply the proceeds of sale in reduction of the Customer Debt.

If the Customer resells or uses the Goods before ownership of the Goods has passed to the Customer, the proceeds of such sale or use will be held by the Customer (in whatever form) in trust for both the Customer and the Supplier. The Supplier’s interest as beneficiary under that trust is that portion of the proceeds which does not exceed the Customer Debt. The balance of the proceeds (if any) shall be the Customer’s beneficial interest under that trust. The Supplier may at any time, by notice in writing, require the Customer to convert the proceeds into money, to be paid into a bank account nominated by the Supplier for disbursement in accordance with these terms.

The Supplier may bring an action for the price of the Goods sold even where ownership of the goods may not have passed to the Customer.

If any of the Goods are mixed or incorporated in other goods (the “Mixed Goods”) before payment for or resale of the Goods, ownership of the Mixed Goods remains with the Supplier on the same basis as is set out above. The Supplier and the Customer will have the same rights, powers, duties and liabilities in respect of the Mixed Goods as if the Mixed Goods had been Mixed Goods owned and supplied by the Supplier in accordance with these terms at the time that the Goods had in fact been supplied by the Supplier.

### **Personal Property Securities Act 1999 (the PPSA)**

The Customer grants a security interest to the Supplier in each and every part of the Goods as security for payment of that part and of each other part or parts of the Goods and for any other amounts owing by the Customer to the Supplier from time to time, and for the performance by the Customer of all the Customer’s other obligations to the Supplier from time to time, (“Customer’s indebtedness and obligations”). For the purposes of section 36(1)(b) of the PPSA, and to ensure maximum the Customer intends to and does grant to the Supplier, as security for the Customer’s indebtedness and obligations, a security interest in all of the Customer’s present and after-acquired property except only for any such property which is or comprises items or kinds of personal property (“excepted property”):

- (a) in or to which the Customer has rights; and

(b) which has not been supplied by the Supplier to the Customer,

other than any excepted property which is or comprises proceeds of any of that present and after-acquired property which has been supplied by the Supplier to the Customer.

The Supplier may allocate amounts received from the Customer in any manner it determines, including in any manner required to preserve any purchase money security interest it has in any Goods.

The Customer waives the right to receive a copy of the verification statement confirming registration of a financing statement or financing change statement relating to the security interest under the Contract.

The Customer agrees that nothing in sections 114(1)(a), 133 and 134 of the PPSA shall apply to this Contract, or the security under this Contract, and waives the Customer's rights under sections 121, 125, 129, 131 and 132 of the PPSA.

### **Consumer Guarantees Act 1993 (the "CGA")**

Where (were it not for this paragraph) the CGA would apply to the contract of sale into which these terms are incorporated, and the Customer acquires (or holds the Customer out to be acquiring) the goods for the purposes of a business as defined in the CGA, the Customer agrees that the CGA does not apply to the contract of sale.

Nothing in these terms (particularly the clauses headed "Warranties" "Liability" and "No Credit for Returned Goods") is intended to have the effect of contracting out of the provisions of the CGA where the CGA applies. Where the CGA applies, these terms are modified accordingly.

### **Warranties**

No warranty or condition is implied against the Supplier under any statute, at common law or otherwise and no representation, condition, warranty or variation of these terms is binding on the Supplier unless it is in writing and signed by a duly authorised officer of the Supplier.

### **Return of goods**

#### **Sale and Return**

Goods are not sold on a sale or return basis unless specifically agreed in writing.

#### **Goods Damaged in Transit**

Goods damaged in transit must be reported to the Supplier within five business days of their receipt quoting packing slip or invoice number. Where it is identified that damage occurred after risk in the Goods passed to the Customer then the Supplier accepts no responsibility for such claim and will advise the Customer of the appropriate person to claim against.

#### **Mispacked Goods**

Short or incorrect Goods must be reported to the Supplier within five business days of their receipt quoting packing slip or invoice number.

#### **Defective Goods**

Any Goods which show obvious manufacturing defects must be notified in writing to the Supplier within two business days from receipt of the Goods. Where possible please quote the packing slip or invoice number.

#### **No Credit for Returned Goods**

Goods cannot be returned unless the Supplier has specifically agreed with the Customer in writing to this effect in advance and in any event credit will be issued only to the value of the Goods less a re-stocking fee of 10% of the net invoice value.



### **Liability**

The Supplier will not be liable for any Claim for loss or compensation or other remedy (of any nature, including under contract or in negligence) by the Customer or any other person including without limitation any Claim relating to or arising from:

- any condition, warranty, description, representation, condition as to fitness or suitability for any purpose, merchantability or otherwise, whether express or implied by law, trade custom or otherwise (excepted as provided in the section headed “Consumer Guarantees Act”); or
- any representation, warranty, or agreement made by any agent or representative which is not expressly confirmed by the Supplier in writing.

If despite this clause the Supplier is held to be liable to the Customer under these terms for loss of any nature (including under contract and in negligence) the Supplier’s total liability will not exceed the price of the goods in relation to which that liability was incurred.

### **Default**

If an Event of Default occurs, the Supplier may suspend or terminate the contract of sale between the Supplier and the Customer.

If the Customer does not pay the amounts payable under these terms by the due date for payment under these terms, the Customer will compensate the Supplier by immediately making payment as liquidated damages (in addition to the amount due) of interest at a rate per annum 4% above the retail lending base rate of the Bank of New Zealand as at the first day of the month in which the default occurs, and calculated on a daily basis on the amount unpaid from the due date until payment is made in full .

The Customer will pay all costs incurred by the Supplier, including legal costs on a solicitor-client basis and debt collectors’ costs, in the recovery or attempted recovery of outstanding money and the enforcement of these terms.

Payments by the Customer will be applied first in reduction of such interest and costs due, and the balance in reduction of other amounts due.

If an Event of Default occurs, the price and any other amount owing will immediately become due and payable notwithstanding that the due date has not arisen.

### **Waiver**

If the Supplier exercises or fails to exercise any right or remedy available to it, this will not prejudice the Supplier’s rights in exercising that or any other right or remedy.

Any waiver of any term of the contract into which these terms are incorporated must be specified in writing and signed by an authorised officer of the Supplier.

### **No assignment**

The Customer must not transfer its rights in respect of the purchase of Goods to any other party without the Supplier’s prior consent in writing.

### **Agreement**

The Supplier may amend these, and introduce new, terms of trade by giving 7 days notice in writing to the Customer.

### **Jurisdiction and forum**

These terms and the contract of sale into which they are incorporated are governed by New Zealand law and the parties submit to the non-exclusive jurisdiction of the New Zealand courts.

### **International sales**

The United Nations Convention on Contracts for the International Sale of Goods adopted at Vienna, Austria on 10 April 1980 does not apply to sales of Goods the subject of these terms of trade.

### **Definitions**

In these terms:

“the CGA” means the Consumer Guarantees Act 1993.

“Claim” means any claim:

- for loss of profits suffered by the Customer; or
- for any consequential, indirect or special loss, damage or injury of any kind suffered by the Customer or any person arising directly or indirectly from:
  - any breach of the Supplier’s obligations under the contract; or
  - any cancellation of this contract; or
- any negligence, misrepresentation or other act or omission by the Supplier or its employees, agents or contractors.

An “Event of Default” means an event where:

- the Customer fails to comply with the terms of the contract into which these terms are incorporated or any other contract with the Supplier or any related company of the Supplier; or
- the Customer commits an act of bankruptcy or is unable to pay its debts as they fall due or is deemed to be bankrupt or insolvent; or
- the Customer enters into any composition or arrangement with its creditors; or
- If the Customer is a company:
  - the Customer commits any act or any event occurs in relation to it which exposes it to a risk of being put into liquidation or receivership; or
  - a resolution is passed or proceedings commenced for the Customer to be wound up or liquidated; or
  - a receiver or statutory or official manager or trustee is appointed over all or any of the Customer’s assets; or
- the ownership or effective control of the Customer is transferred without the prior written consent of the Supplier.

“Ownership” means the property in and legal and beneficial ownership.

“the PPSA” means the Personal Property Securities Act 1999.







Jean Müller NZ Ltd.  
Unit 2, 37 Hurlstone Drive  
PO Box 907  
New Plymouth 4340  
NEW ZEALAND

Phone 06 769 9694  
Fax 06 769 9696

Website [www.jeanmueller.co.nz](http://www.jeanmueller.co.nz)